





120kW DC CHARGING

Installation and User Manual

Thank you for choosing our DC charging station product. To help you install and use the charging station correctly, please read this manual carefully and keep it safe. If you still have any questions about any of the contents, please contact our company in a timely manner and seek help. Our company reserves the right to modify the technical features and content in this manual.



















CATALOGUE

I. Security Statement	- 1 -
1.1 Safety Identification	- 1 -
1.2 Safety Warning	- 2 -
1.3 Liability Statement	- 2 -
II. Product Overview	- 4 -
2.1 Product Parameters	- 4 -
2.2 Functional Features	- 5 -
2.3 Product Description	- 7 -
III. Installation Instructions	- 11 -
3.1 Construction Preparation	- 11 -
3.2 Installation and Preparation	- 13 -
3.3 Installation Steps	- 16 -
3.4 Installation and Adjustment	- 22 -
IV. Direction for Use	- 23 -
4.1 System Startup	- 23 -
4.2 Charging Operation	- 24 -
4.3 OCPP Network Settings	- 28 -
4.4 Operational Integration	- 33 -
V. Maintenance Instruction	- 34 -
5.1 Daily Maintenance	- 34 -
5.2 Maintenance and Maintenance	- 35 -
VI. Fault Treatment	- 36 -
6.1 Fault Identification	- 36 -
6.2 Treatment Method	- 37 -
6.3 Maintenance Records	- 38 -
VII. After-sale Service	- 39 -

I.Security Statement

1.1 Safety Identification

	<p>Refer to Instruction Manual</p> <p>It typically signifies that user guide manuals or original documents must be kept properly for future use, and must not be damaged in any way</p>
	<p>General Warning</p> <p>Important security information that must be very carefully observed</p>
	<p>Dangerous Voltage</p> <p>Indicates situations where dangerous voltage must be handled with extreme caution</p>
	<p>High Temperature Warning</p> <p>Represents the burn hazard in high temperature areas or areas with high component temperatures</p>
	<p>Hazard of Injury Due to Equipment Weight.</p> <p>Indicates careful lifting and transport are required to avoid injury</p>
	<p>Prohibition Notice</p> <p>It means that entering the relevant area or performing the operations is prohibited</p>
	<p>Avoid Child Contact</p> <p>Indicates that the equipment should be kept out of reach of children</p>
	<p>No Smoking and Using Open Fires are Allowed</p> <p>Indicates prohibition of smoking and use of open flames near the equipment</p>
	<p>Personal Protective Equipment</p> <p>Indicates that the operations must be performed using clothing and / or personal protective equipment provided by the employer</p>
	<p>Ground Protection Connection Point</p> <p>Indicates the designated connection point for ground protection</p>
	<p>Allowable Temperature Range</p> <p>Indicates the range of temperatures within which the equipment can operate safely</p>
	<p>Direct Current</p> <p>Indicates the use of direct current(DC)</p>
	<p>Alternating Current</p> <p>Indicates the use of alternating current(AC)</p>
	<p>Positive Electrode of the Input Voltage</p> <p>Indicates the positive electrode for input voltage/current</p>
	<p>Negative Electrode of the Input Voltage</p> <p>Indicates the negative electrode for input voltage/current</p>
	<p>Note Content Identification Suggestions or Comments</p> <p>Indicates notes or suggestions for the content</p>

1.2 Safety Warning

The company's EV Chargers are designed and tested in strict accordance with the relevant national and international safety standards. However, the safety of power electronic equipment is not only affected by the quality of the equipment itself, but also highly related to handling, installation, trial operation, operation, maintenance, demolition and other operations. Incorrect use or misoperation will lead to the following risks:

- Risks of electric shock, short circuit, fire, explosion, and severe burns;
- Harm to the life and personal safety of the operator or a third party;
- Damage to the EV Charger or other property.

To avoid safety accidents, the following safety precautions should be strictly observed during installation and maintenance.

- All preparation, installation, movement, maintenance and disassembly, must be completed by professional and technical personnel. Unauthorized loading and unloading are prohibited.
- Professional and technical personnel must be qualified and trained or proven to have skills and knowledge in the structure and operation of EV Chargers;
- Read this manual completely and understand the relevant safety matters.

1.3 Liability Statement

Owner Responsibility

Requirements for Charging station owners and field operators:

- Run the charging station with full implementation of protective measures ensuring the correct installation and regular maintenance of protective facilities;
- Prepare an emergency plan to handle emergencies effectively;
- Prepare the installation site according to the requirements described in this manual;
- Ensure sufficient space for passage and maintenance of the EV Chargers;
- Assign a person responsible for safe operation and overall coordination;
- Understanding that unauthorized changes can affect the operation authorization or warranty.

Disclaimer

The Company shall not be liable for accidents or damage caused by:

- Human factors or abnormal working environments;
- Faults and damage caused by not following the instructions;
- Damage due to poor transport after delivery;
- Normal wear and tear, rupture and immersion dyeing;

- Products not belonging to the company (eg: counterfeit goods);
- Unauthorized disassembly, repair, or modification
- Damage due to other non-resistance (such as flood, fire, lightning strike, typhoon, earthquake, abnormal voltage);
- Use beyond the service life not covered by warranty;

II.Product Overview

2.1 Product Parameters

Order Number	Product	Dc Charging Pile For Electric Vehicles
1	Input Line System	Three-phase five-wire 3P + N + PE
2	Input Voltage	400V AC \pm 15%, 50Hz
3	Rated Power	120kW DC
4	Power Factor	~0.99 (Full load)
5	Output Voltage	200—1000VDC
6	Constant Power Area	300—1000VDC
7	Maximum Current of Single Connector	250A DC
8	Cabinet Dimensions	800mm*630mm*1830mm (excluding Connector holder)
9	Levels of Protection	IP54
10	The charging Cable Length	5m
11	Noise	\leq 75dB
12	Working Temperature	-20 $^{\circ}$ C~+50 $^{\circ}$ C
13	Storage Temperature	-40 $^{\circ}$ C~+70 $^{\circ}$ C
14	Working Humidity	Relative humidity 5% to 95%
15	Working Altitude	Up to 2000m (above 2000m needs special consideration)
16	Gas Medium	Should avoid explosive, corrosive and harmful gases and conductive media
17	Open Installation	Suitable for all-weather open-air installation
18	Verticality	Mounting vertical inclination should not exceed 5 $^{\circ}$
19	Cable Entry	Bottom entry for cables
20	Cable Outlet	The upper cable outlet of the cabinet is designed to be waterproof and resistant to immersion, rain, and snow. It also prevents tripping hazards for pedestrians and vehicles.

2.2 Functional Features

Safety

- Unique safety mechanisms including pre-charging protection, main circuit safety detection and remote diagnosis management
- Basic protection measures such as lightning protection, overvoltage, overcurrent, short circuit, connection fault, and emergency stop
- Comprehensive charging protection functions and mechanisms that effectively guarantee the safety of personnel, prevent overcharging, and ensure operational safety

Intelligence

- The terminal EV Chargers and the cloud platform intelligent Internet of Things can perceive more than 100 underlying operating parameters in real time
- Features remote diagnosis, remote reset, and remote upgrade capabilities.

Reliability

- Independently designed hardware and software, from circuit boards to system architecture, and from embedded software to cloud platform, ensuring high consistency, compatibility and stability
- Performance Metrics such as current accuracy, voltage accuracy, leakage protection accuracy, ripple harmonic, and standby power consumption exceed industry averages.
- Utilizes international first -line brand components for high system reliability. The wind duct maze design effectively prevents issues such as splashes and accidental collisions, making it suitable for installation in urban public parking lots and roadside parking spaces.

Convenience

- Flexible networking options with both wireless and wired communication modes.
- Anti-sunlight liquid crystal display with a user-friendly interactive interface
- Open communication protocol supporting code scanning charging, API services, and energy demand response

Interactive Function

- All charging stages include intuitive and friendly illustrations and text prompts on the screen.
- The screen features an anti-sunlight display and is ergonomically arranged for ease of use.

Measurement function

- DC metering function with an accuracy level of 1.0.

Communication Function

- Supports Ethernet access and 4G wireless communication networking.

Payment Function

➤ The EV Charger provides charging consumption time and quantity information to the operation background which centrally controls the charging strategy. The integrated system supports various payment methods such as card swiping, code scanning, and mobile app payments.

- Customizable optional POS machine supporting VISA and international credit card payments.

Self-Test and Self-Repair Function

➤ During power operation, the EV Chargers conducts a self-check of the equipment's working environment, power supply, data storage space.

➤ Fault information is displayed on the screen, recorded, and stored in the superior monitoring and management system.

➤ Automatically monitors the operation of key components, including but not limited to charging connectors connection self-test, contactor adhesion self-test, and power unit state self-test.

Remote Internet of Things Function

➤ The EV Chargers connects with the device cloud platform to monitor numerous parameters in real time providing comprehensive remote diagnosis, remote service, and remote upgrade service

Diagnostics include checks for whether the charger cabinet door is opened, whether the emergency stop button is pressed, whether the AC contactor is disconnected, whether the vehicle is connected, whether the connector head temperature is too high, and whether the insulation test is normal.

2.3 Product Description

Product Appearance



A.LED Indicator Light

B.Human-machine Interface Display Screen

C.POS Machine (Configuration Options)

D.Emergency Stop Button

E.Cabinet Lock

F.Charging Cable

Note: Due to the version iteration, there may be some differences between photos and physical objects.

Inner Structure

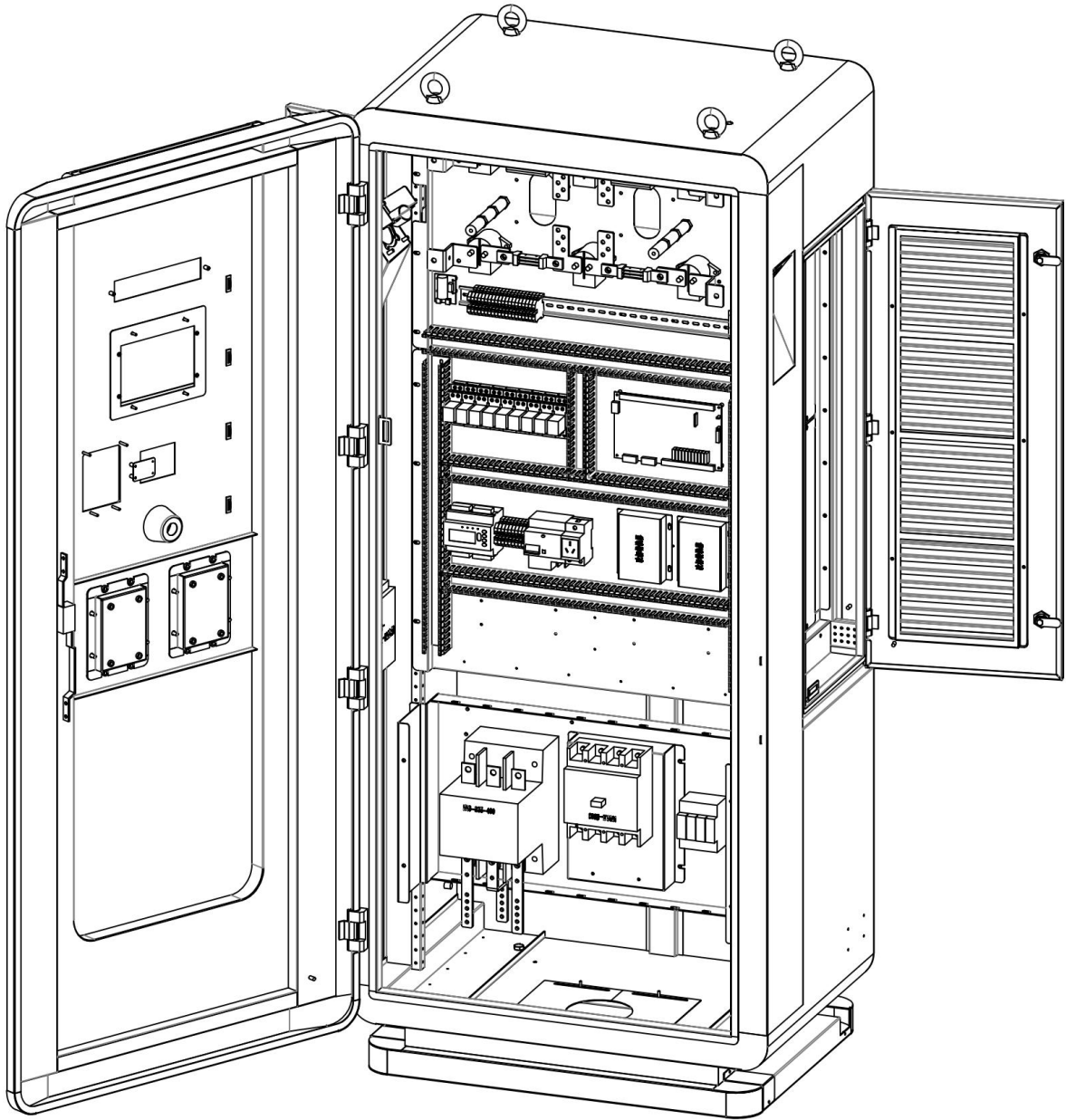

Note: Due to the version iteration, there may be some differences between photos and physical objects.

Space Requirement

To ensure the safe and reliable operation and convenient maintenance of the equipment, sufficient space for installation must be reserved.

The space requirement during installation is 1800mm * 1680mm, calculated as follows:

- **Dimensions(W * D * H):** 800mm * 630mm * 1830mm (excluding connector holder)
- **Front Side Clearance:** Reserve 1000mm to ensure the normal operation of the front door switch and smooth functioning.
- **Left Side Clearance:** Reserve 500mm to allow for normal operation of the front door and smooth functioning.
- **Right Side Clearance:** Reserve 500mm to enable normal operation of the side door , maintenance space for the charging module, and smooth airflow into the air inlet.
- **Rear Clearance:** Reserve 50mm to ensure that the side doors on both the left and right are not obstructed.

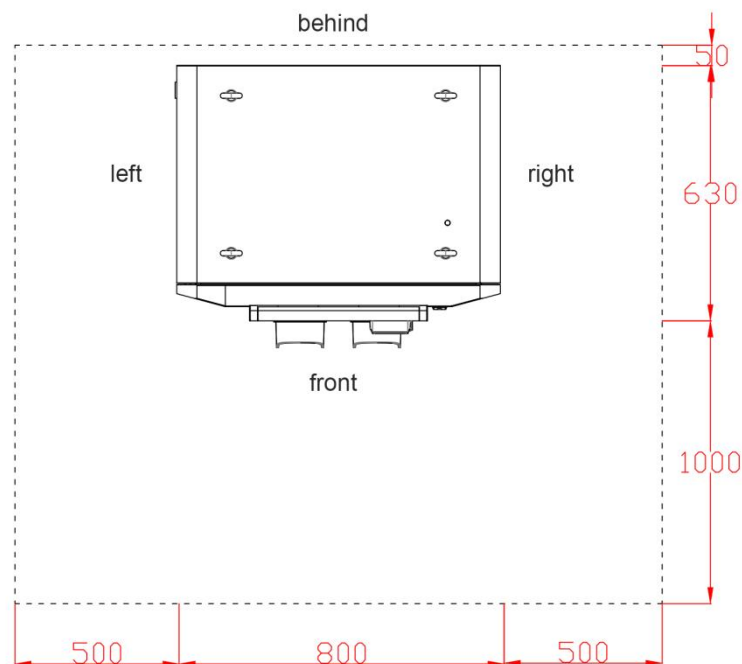

Ventilation Requirements

The EV Chargers converts AC to DC to charge electric vehicles. During this conversion process, some energy is lost as heat, necessitating efficient heat dissipation. Therefore, it is essential to ensure that the installation space has open and continuous airflow, and that the main air inlet and outlet paths are not blocked. It is not recommended to install the charger in a confined space without ventilation. The product's air inlet is located on

the right side of the screen, and the air outlet is on the left side.



pay Attention to

Ensure Unobstructed Airflow:

Preventative measures should be taken to keep the air ducts clear. Avoid any obstructions, such as snow or foreign objects, from blocking the air inlet and outlet.

III. Installation Instructions

3.1 Construction Preparation

About the Construction

The construction phase includes all tasks necessary to prepare the installation site for placing and connecting the EV charger. The following conditions must be met to begin the construction phase:

- All engineering preparations are complete
- All necessary permits have been obtained
- The grid can be connected

Cable Entry

The cable should enter through the bottom of the EV charger.

Infrastructure Projects

The suitability of the installation site is related to the surface type of the infrastructure construction.

Foundation Requirements

-Indoor Installation: A foundation is not required if the equipment is installed indoors or in other high and dry places. The ground smoothness error must not exceed $\pm 1.5\text{mm}$ per square meter, and the ground strength at the installation position should be at least C30.

-Outdoor Installation: When installed outdoors or in areas prone to water accumulation, a cement or tank steel base must be used. The cement base should be 200mm high, with a recommended depth below ground of at least 500mm. Four M12 stainless steel bolts should be embedded in the installation surface, extending $40 \pm 3\text{mm}$ above the ground. The foundation design should be tailored to the actual site conditions.

-Instructions:

- Excavate a pit at the installation site as specified.
- Ensure the cable can enter through the embedded pipe, with an aperture of at least 100mm.
- Pour the concrete foundation as illustrated.
- Ensure the EV charger's base height is at least 200mm to reduce flooding risk.
- Expose 0.8m of cable length above the foundation for internal wiring.

Fill the foundation's inner and outer holes with sand and stone, and seal the inlet holes with fireproof mud to prevent small animals from entering the equipment.

Base Hole Position and Installation Method

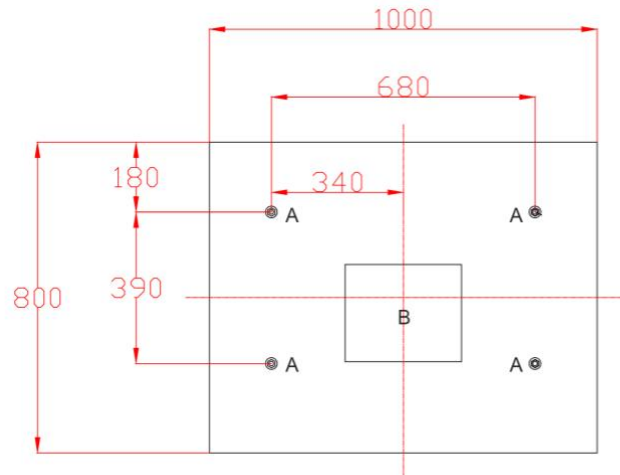

- Figure A: Embed four M12 stainless steel bolts.(screw anchor)
- Figure B: Identify the power cable entrance location.
- Exposed cable length for internal wiring is 0.7M

Cable Protection Requirements

- **Cable Type:** three-phase and five-wire system (3P + N + PE),
Verify if shielding is required based on local laws.
- **Shielding Layer:** Connect both ends of the shielding network with the PE safety ground wire if present.
- **Cable Diameter:** Determined by the contractor or electrical engineer based on power, distance, and industry standards.

industry standards.

- **PE Safety Ground Wire:** Should match the N wire model size.
- **Recommended Cable Cross-sectional Area:**
 - For 120kW: YJV 4 * 95 + 1 * 50
 - For 160kW: YJV 4 * 120 + 1 * 70
 - The cable must comply with national and local standards.
 - Each EV charger must have independent open and leakage protection.

Network Connection Requirements

-**Standard:** 4G wireless communication module integrated with the EV charger. Users should prepare a SIM card. If no 4G signal is available, use a standard wired Internet connection.

-Wired Connection Requirements:

- The RJ 45 Ethernet:** 8P + PE, shielding wire.
- **Recommended Length:**

Up to 75m, refer to HELUKAT 600E.

For lengths over 75m, an engineering scheme is required.

--The Minimum Bandwidth:

Uplink: 128 kbps

Downlink: 4 Mbps

--Connection Dependability: 99.9%

3.2 Installation and Preparation

Transport Loading and Unloading

- Handle heavy equipment with care.
- Use appropriate load-bearing equipment such as forklifts, cranes, or towing trucks, operated by professionals.
- Avoid dumping or crashing the equipment.

Keep the device upright, with a tilt angle not exceeding 30 degrees.

Arrival Inspection:

- Check for package damage and label correctness upon arrival. If any abnormality is found, inform the carrier, take photos, and collect evidence. Sign the documents and contact the manufacturer for further action.
- Verify that product accessories and accompanying documents are complete according to the packing list.
- Inspect the product visually for any signs of collision, scratches, cracks, corrosion, damage, or paint peeling.
- Check the charging connector for any abnormalities such as crushing, rust, damage, or loose connections.
- Sign documents, save records, and distribute or transfer them to related parties.

On-site Confirmation

- Ensure that the site's altitude, coordinates, temperature, humidity, ventilation, load-bearing capacity, installation position, maintenance space, and power supply meet the equipment's requirements.
- Confirm that the on-site 4G signal strength is good (signal strength greater than -85 dBm, or above 50% full grid strength as observed on a mobile phone).
- Verify that all necessary licenses are in place.
- Confirm that the project preparation work is complete and the power grid connection is available.
- Avoid starting installation if construction is ongoing at the site to prevent damage from building

materials, dust, paint, muck, or litter. It is recommended to install the EVcharger after construction is completed.

For short-term or long-term storage, store the equipment in a dry, well-ventilated indoor place, away from high temperatures, humidity, dust, metal powder, and corrosive gases.

Important Notes:

➤ Due to the complexity and danger of EV charger installation, only qualified professional and technical personnel should perform the installation according to this manual.

➤ Prepare and check relevant tools and devices, ensure personal protection, and wear protective gloves during installation to prevent injuries from metal parts. Use appropriate lighting devices if needed.

➤ Ensure all switches associated with the equipment are in the off state (when repairing or replacing spare parts, ensure the equipment is well grounded).

Use professional tools to confirm the power supply is disconnected, with no power input and output to the equipment. Ensure each charger has independent protection and disconnection conditions, and use a special power interface with proper grounding. Fire and neutral wires must not meet. Turn off the power and take reasonable measures to prevent the power switch from closing automatically.

Installation Tools

Name	Main Role	Quantity
Multimeter	Check Electrical Connections and Parameters	1 pc
Electric Impact Drill	Drill Holes	1 pc
Impact Bit (Φ 16mm)	Drill Bit	2 pcs
Band Tape	Measure	1 pc
Leveling Instrument	Measure	1 pc
Slotted Screwdriver	Open	1 pc
Plier	Open	1 pc
Wire Stripper	Remove Insulation Sheath	1 pc
Terminal Crimping Pliers	Crimp Terminals	1 pc
Diagonal Pliers	Cut Cables	1 pc
Adz-eye Hammer	Unpack, Tap and Adjust	1 pc
Transport Equipment	Move and Hoist EV Chargers	1 set
PVC Insulation Tape	Insulate Connections	1 roll
Personal Protection Tools	Ensure Operator Safety and Health	1 set
Multi-Function Crowbar	Remove Wooden Box	1 pc

Basic Tools

Order Number	Nut /Bolt	Tool	Installation Site
1	M12 Hexagon Nut	19 # Tools Included With The Charger	Base Installation (fixed to cement base)
2	M8 Inner Hexagon Bolt	6mm Inner Hexagon Spanner	Input Ground Wire, ABC Phase Power Input, N Wire Installation
3	M10 Inner Hexagon Bolt	8mm Inner Hexagon Spanner	120kW Cable, ABC Phase Power Input, N Wire Installation

Installation, Repair, and Replacement of Spare Parts

Safety Precautions:

- Live work is strictly prohibited
- Unauthorized disassembly is strictly prohibited.
- Ensure equipment operation safety.
- Follow the sequence PE ground wire > zero wire > phase wire for power supply line access.
- All operations must comply with the relevant safety standards

Post-installation, Repair, and Replacement

- Perform acceptance and testing according to installation and maintenance requirements.
- Organize and collect tools, restore the internal switch to the working state.
- Lock the safety door to maintain equipment safety.

3.3 Installation Steps

Receiving the Goods

EV charger products can be delivered by the transportation company to the destination warehouse or the agreed location. For standard orders, the factory is not responsible for delivering the equipment to the final installation point. Prepare personnel and equipment for unloading and transfer at the receiving site.

Removing the Packaging

Use a multi-functional crowbar to remove the outer packaging, and use scissors or an art knife to remove the inner packaging.

Installation Preparation

- Open the side cover plate of the base, release the clamp cylinder, open the stack plate screw, etc.
- Unscrew and keep the screws on the base side cover plate.
- Remove and safely store the side cover plates and the front door of the EV charger.
- Open the front door of the EV charger
- Check for any abnormalities such as loose threads or parts.
- Reattach the side door and front door in sequence.
- Unclip the bolts securing the cabinet to the stack plate.

Placing the Equipment in Position

Move the equipment to the pre-made concrete base using one of two methods:

- 1: Lift the EV charger into position using optional lifting rings.
- 2: Use a lifting forklift to carry the EV charger into place.



High Voltage Safety

Ensure that the main and auxiliary circuit switches of the EV charger are disconnected. Perform voltage detection to confirm no current is present in the wires and system.



Warning

Handling the EV charger after delivery is not covered under warranty. Handle with care during transportation and installation.

Handling EV Charger

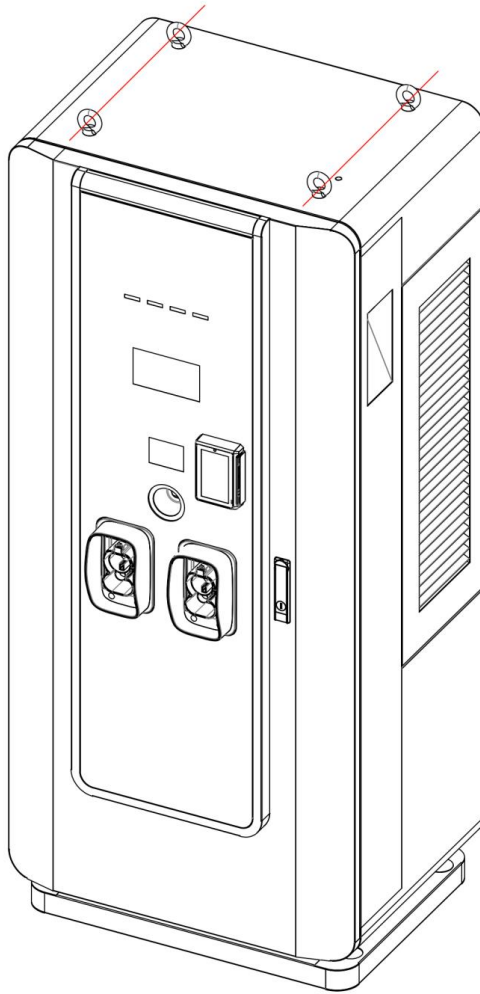

- Open the base-side cover plate
- Use the forklift truck to pass through the designated red line position as shown
- Carefully move the EV charger to the installation position

Locking the equipment

Preparation

- Tool: 19# wrench (for fixing M12 hexagon nuts).
- Raise the EV charger by about 0.5m and place it above the installation position.
- Pass the traction power cord through the cable envelope.

Placing the Cabinet to the Base

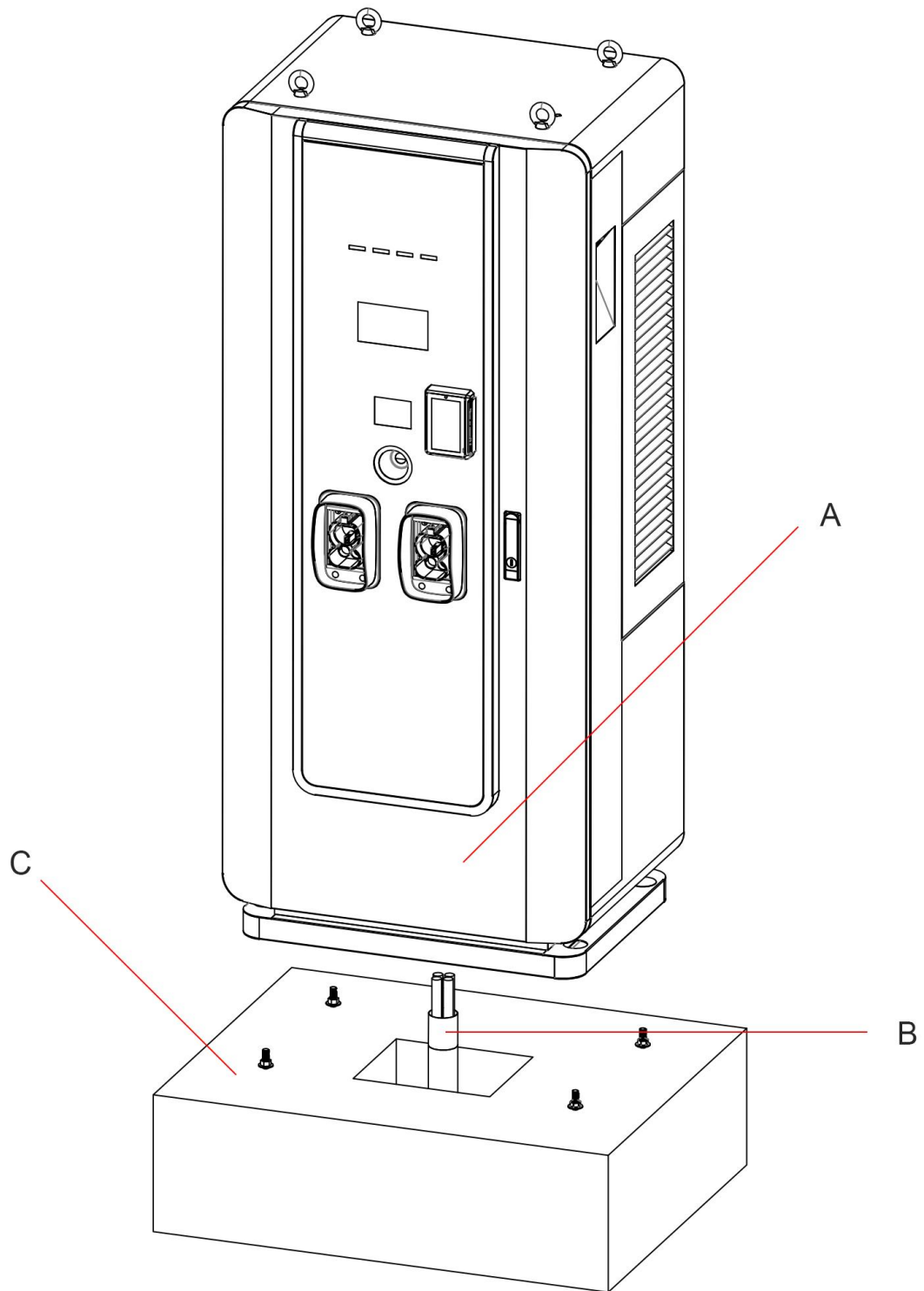

A. EV Charger

B. Cable

C. Concrete Pedestal

Placing the Cabinet to The Base

Installation Method 1

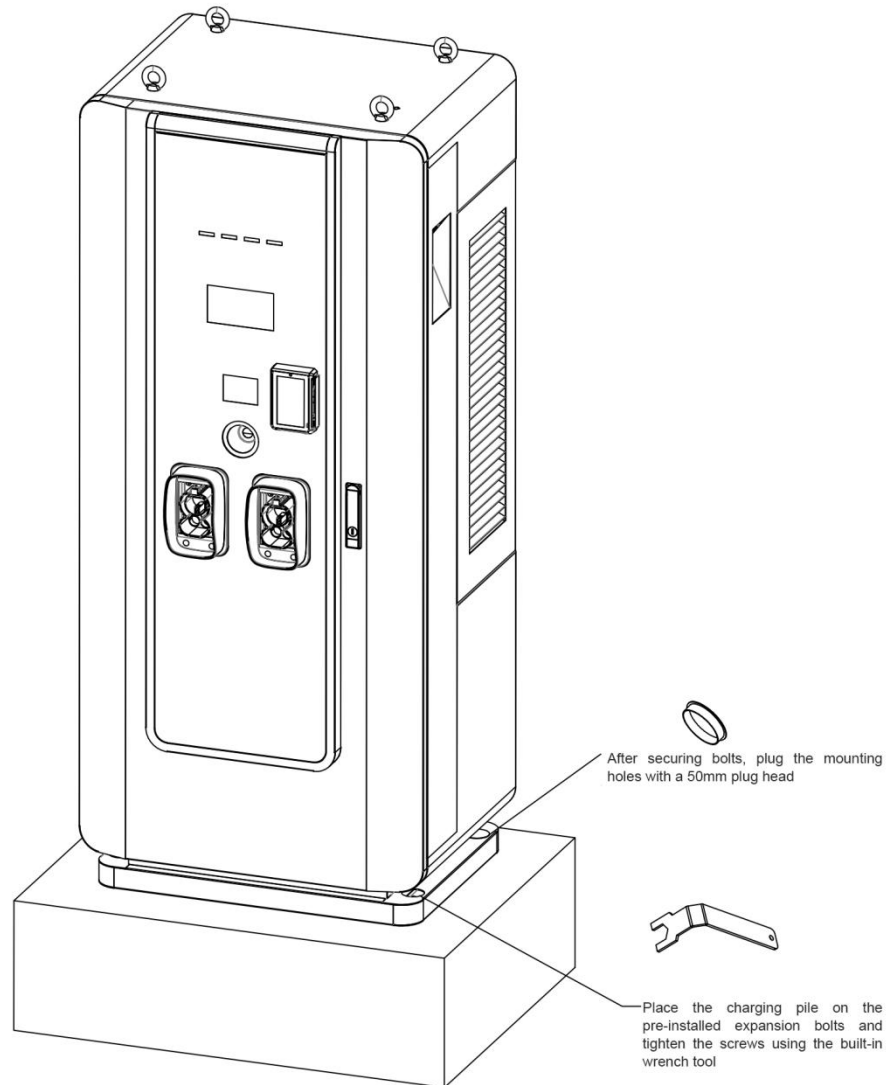

- Slowly lower the EV charger into place.
- Ensure the cable is exposed inside the cabinet along the envelope
- Align the cabinet holes with the bolt holes.
- Insert flat washers, spring gaskets, and M12 nuts.
- Tighten the nuts with a torque of 95.5Nm.

Installation Method 2

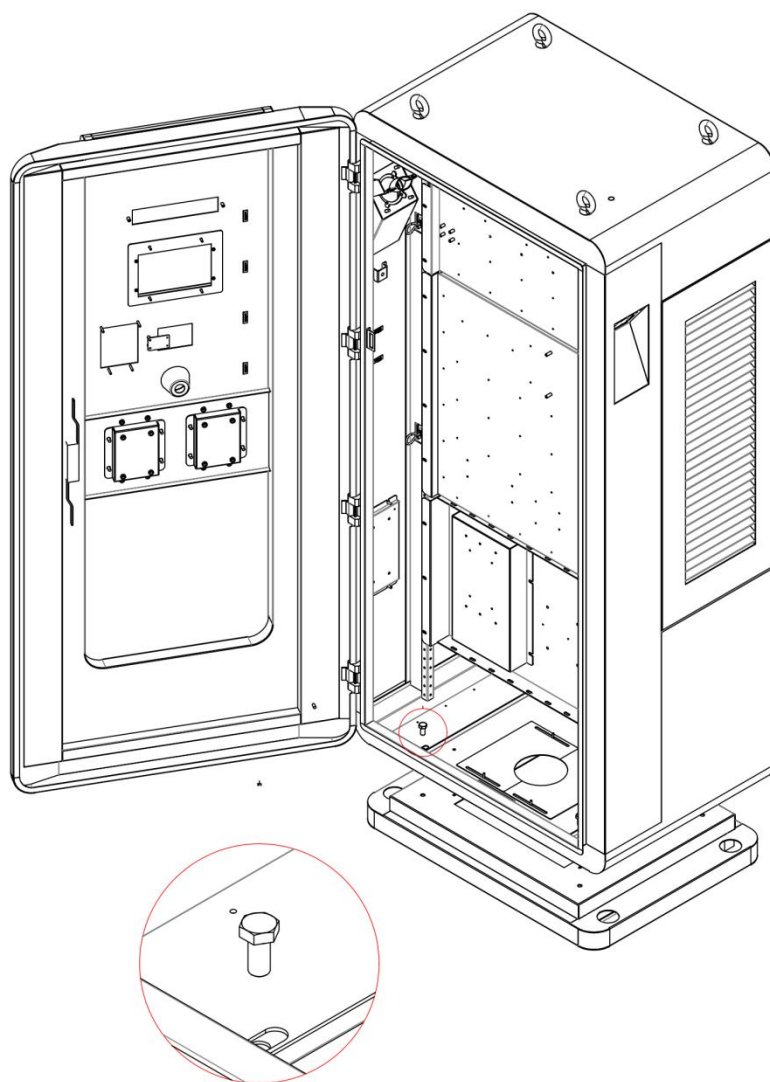

- Remove the four M10 screws that secure the base to the housing
- Fix the base and concrete foundation with M12 expansion bolts
- Lift the shell and fix it to the base using the removed M10 screws

Connecting the Cable

Description: Different configuration versions require different wiring modes.

The reserved cable length is 0.8m.

- **Tools:** wire cutters, terminal / copper nose, terminal pressing clamp
- Remove 20mm of insulation at the cable end with a wire stripper.
- Crimp the cable end with suitable SC copper terminals.
- Connect the cable to the designated area as shown:
A/B/C for phase wire, N for neutral wire, PE for ground wire.
- The PE position is in the ground wire row at the bottom of the EV charger.
- Tighten the screws to a torque of 5Nm.

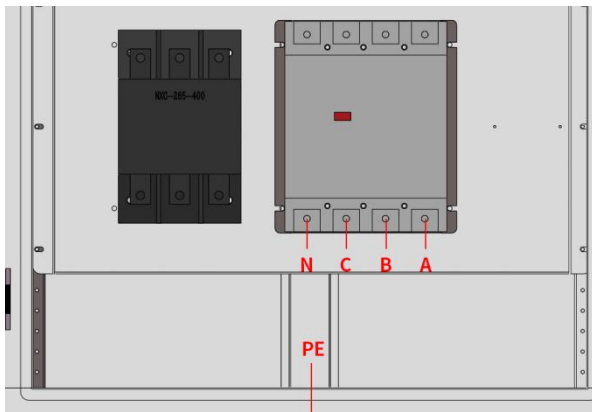

High Voltage Safety

Ensure that the main and auxiliary circuit switches of the EV charger are disconnected. Perform voltage detection to confirm no current is present in the wires and system.



Safety Note

For safety, it is recommended that the PE ground wire be left longer than the general phase wire to ensure the PE ground wire is connected first and disconnected last in case of an accidental collision.

Connecting Ethernet Cables

- **Tools:** network wire pressure clamp, RJ 45 connector, network cable
- **Procedure:**
 - Cut the network cable to the appropriate length for connection to the Ethernet interface.
 - Use the cable clamp to crimp the RJ 45 connector to the cable.
 - Connect the RJ 45 connector to the Ethernet interface.



Note:

This step is required only if the 4G network signal is poor or unavailable.

3.4 Installation and Adjustment

Installation and debugging are necessary final stages before the EV charger enters operation. The purpose is to check the safety and performance of the charging system for operational purposes.

Before Commissioning:

- Ensure all preparation, construction, installation, and connection tasks are completed.
- Connect the EV charger's input power supply and ensure the power charging capacity is ready.
- Assign a local project team technician for on-site assistance and power-on operation.
- Prepare a network cable connection if there is no 4G signal.
- Prepare a European standard pure electric vehicle for on-site trial charging tests.
- Arrange operation representatives for on-site guidance on charging operations.



Note:

The EV charger cannot be moved after debugging without negotiation. Unauthorized movement voids the warranty. For reinstallation to a new location, please contact our services in advance. Once commissioned and verified, the EV charger can be put into operation.

IV.Direction for Use

4.1 System Startup

First Startup:

Execution by our professional or authorized personnel is required. For the first startup after installation in a new location, confirm that preparations are complete according to the "Installation Instructions". Contact the service engineer at least one week in advance to schedule installation, commissioning, and the on-site acceptance test (SAT). Do not complete the installation without performing the SAT.

Normal Startup:

Under normal conditions, connect the power supply, turn on the system power switch, and start the charging cabinet.



Caution:

- Do not touch the contact parts of the charging connector or immerse them in liquid to prevent electric shock.
- Do not place any objects in the charging connector or immerse it in liquid.
- Do not use the charger if there is any foreign object in the charging connector or if the contact is corroded or damaged.

4.2 Charging Operation

When the screen display is normal, no fault information is reported, and the EV charger is in standby mode, the appearance and surrounding environment are normal, the EV charger can start the charging operation.

If the screen displays fault information, do not use the charger and contact the service number for assistance.

Welcome Interface

System Initialization:

- Turn on the system power supply.
- The interface will display port status information after initialization.

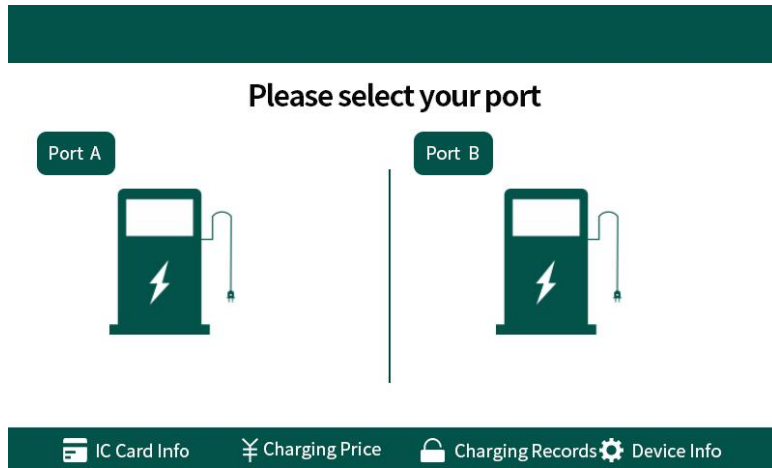

Port Selection

- Click "Inserted Connector..." on the interface to enter the "Select Charging Mode" screen.

As shown in the figure below:

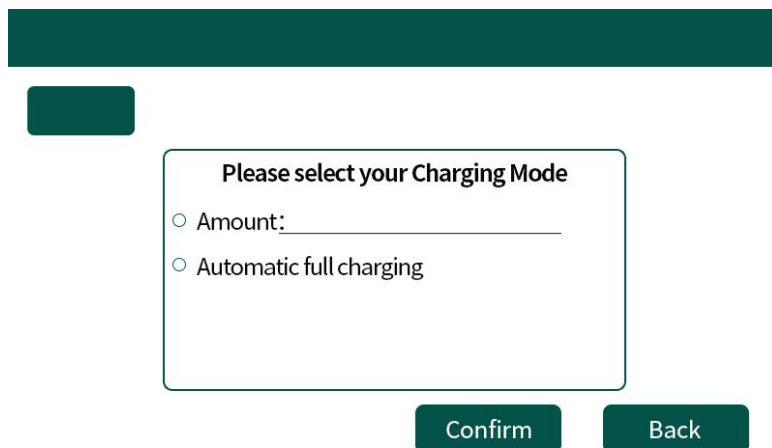

Credit Card Charging

Charging Mode:

- In the "Select Charging Mode" screen, you can enter the amount.
- Charge using a VISA card via POS terminal or click "Autocharged".
- If no POS terminal is configured, use the charging card in the EV charger area.

Scan the Code to Charge

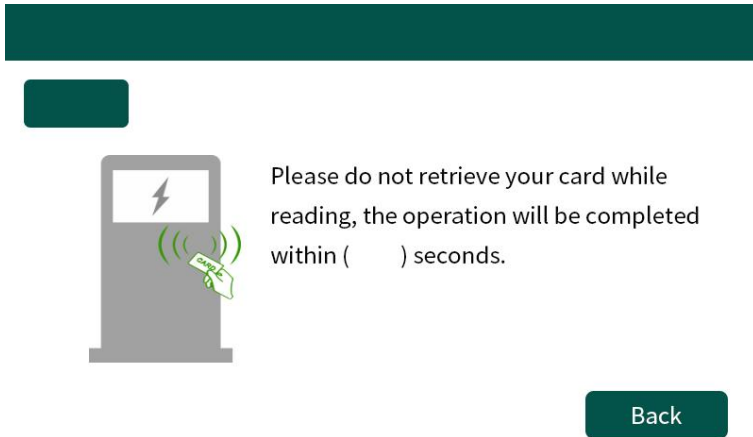

Charging Interface:

- After starting the charge, the interface displays the connected port information.
- Click "Fee Information" and "Battery Information" for more details.

As shown in the following figure:

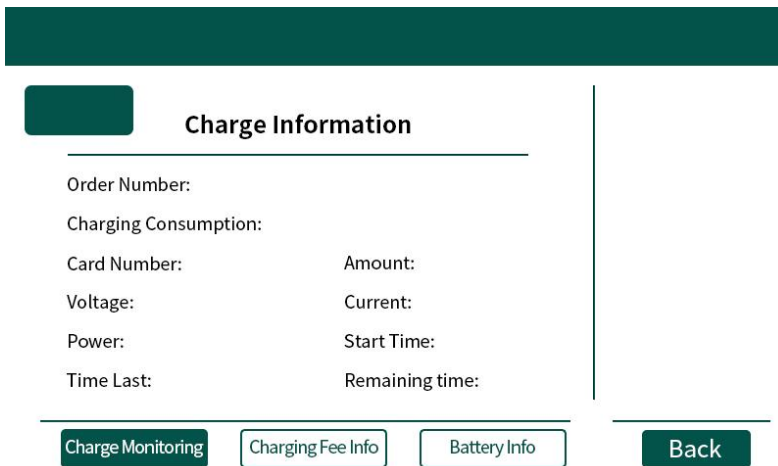

End of Charging

Finishing:

- Double-click "End Charging" in the charging interface to display the settlement information.

As shown in the following figure:

Charging Bill

Settlement: Amount:
Start SOC: Charging Consumption:
End SOC: Start Time:
Order Number: End Time:
Reasons to End:

Back



Attention

High Voltage:

Do not pull the connector directly when high voltage is present to avoid damage or serious injury.

Shutdown:

Operate shutdown via the screen or the APP.

Heat:

The EV charger surface may be hot during charging; do not cover vents.

Cleaning:

Do not clean the vehicle or the charger during charging.

Charging connector in place

Take the charging connector and charging cable back to the EV charger, the charging cable is hung back to the hanging ear, the connector head is inserted back into the body seat, and the charging is completed.

➤ When the charging connector is connected with the vehicle, it is necessary to pull the connector back into the fuselage seat, to prevent the connector head from getting dust or water. To prevent the cable of the charging connector from tripping over pedestrians or other accidents, be sure to hang the charging connector and the cable in the hanging ear and the charging connector seat.

➤ After use, hang around the cable reasonably to keep it in good condition.

➤ In order to save energy, the EV charger screen will automatically enter the screen state after about 18s after no operation. The plugging life of the charging connector is 10,000 times, exceeding the service life or the warranty life (which one comes first), additional spare parts should be purchased.

-The damage of the charging connector caused by violence and illegal operation is not in the scope of our warranty;

-For the life damage caused by dangerous and violent operation, the financial damage shall be borne by the

operator;

- -No irregular use of violent beating, cable twisting and illegal dragging of the charging connector;

- -The operator shall be responsible for the failure caused by the immersion of the charging connector in water without protection;

- The failure or accident caused by exceeding the use conditions specified in this use manual shall be borne by the user.

- Minors under the age of 16 are prohibited from operating the equipment, and any responsibility caused shall be borne by the operator

Charging Abnormalities:

Charging abnormality is not a part of the normal charging operation, but only refer to this part in case of abnormal occurrence or misoperation.

- Emergency stop: Only in case of emergency, quickly remove the transparent protection cover and press the red "emergency stop button", the system will cut off the power supply and output power supply. Do not use the Emergency stop button for normal shutdown.

- Undo the emergency stop: rotate the emergency stop button clockwise to return to the charging state

- Forced connector recovery:

- It is very dangerous to pull out the charging connector during the charging process and must be prohibited!

- If the normal screen stop, swipe card stop operation, can not stop normally, it is recommended to press the emergency stop button.

- There is a risk of arc burn to forcing the connector, and the system will report the above picture (check the fault record);

- Click the confirm button to return to the charging shutdown state.

4.3 OCPP Network Settings

Example Set up access the wss: // dev.optima.az:8314/OCPP/intekdc22

SIM Card:

- ① Insert the SIM card into the OCPP control board;

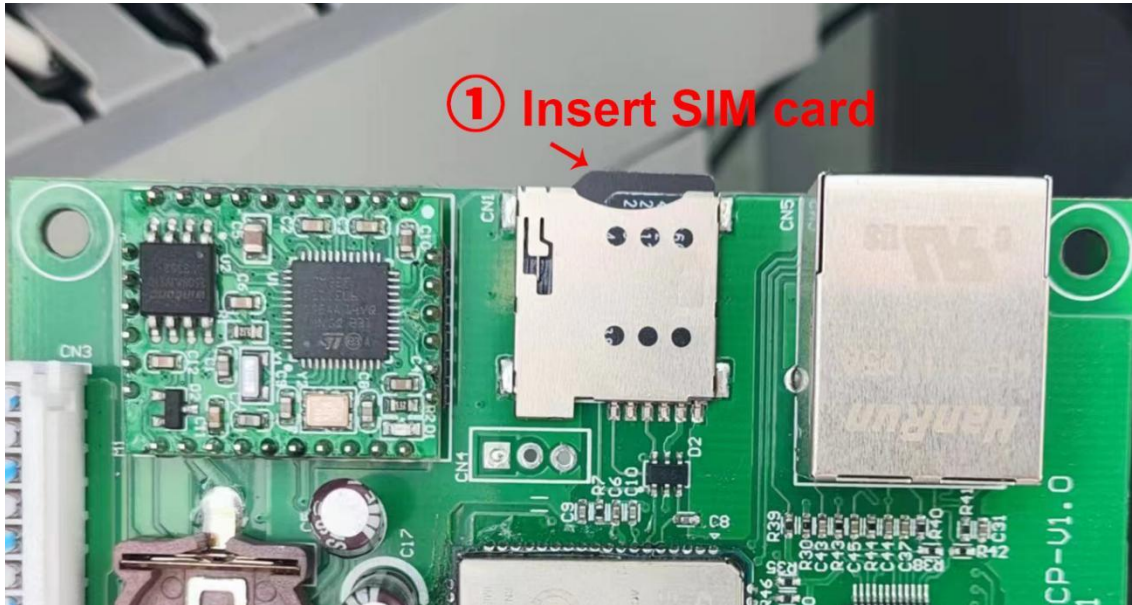

- ② Turn on the single-phase air switch, proceed after the screen is on.



- ③ Double-click the green space above the screen center (as shown below)

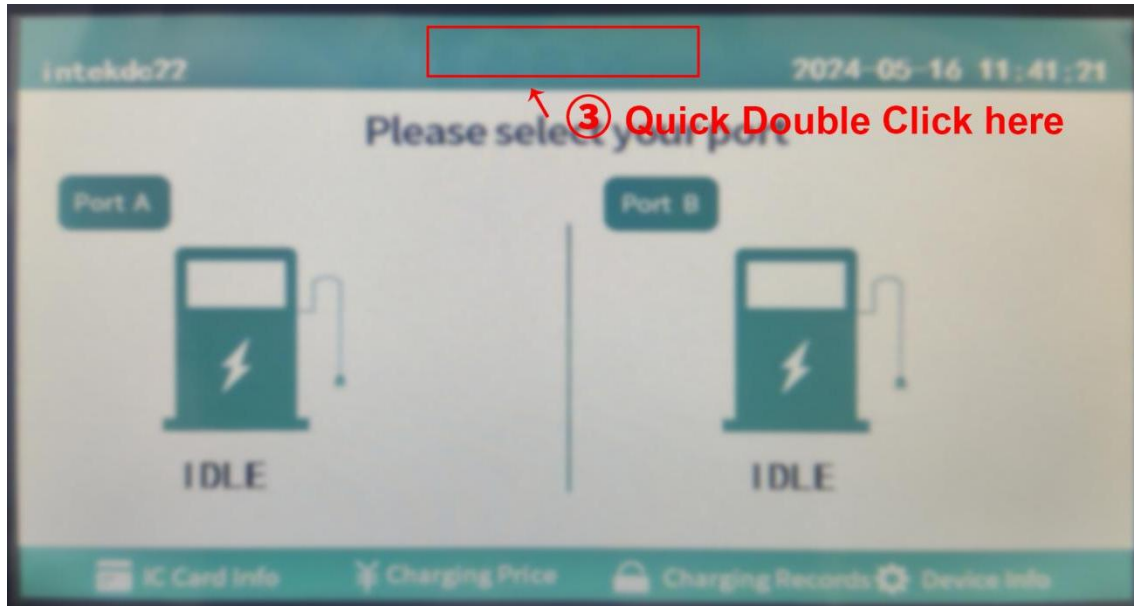

- ④ Click the blank of the input display box and enter 159357

- ⑤ Click "confirm" to enter the Settings interface;

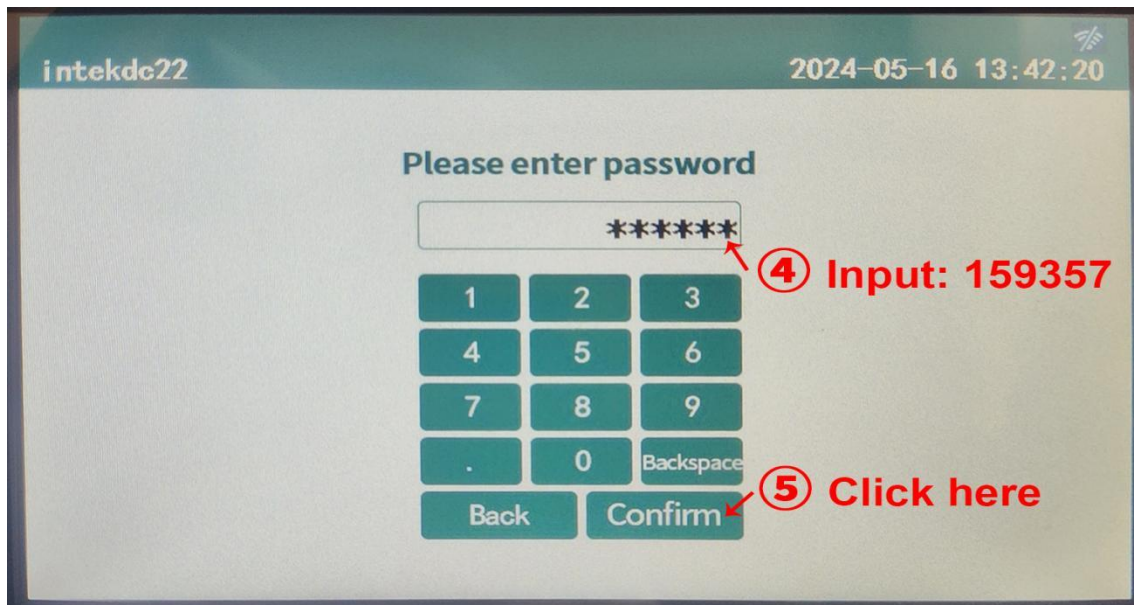

⑥ Set the Charger ID of OCPP (pile given by OCPP provider), and the url of Charger is wss: // dev.optima.

A z: 8314 / OCPP / intekdc22, then enter intekdc22;

⑦ Set the platform to OCPP , if not already set;

⑧ Click "Network Settings", after setting the charger number and charging platform,

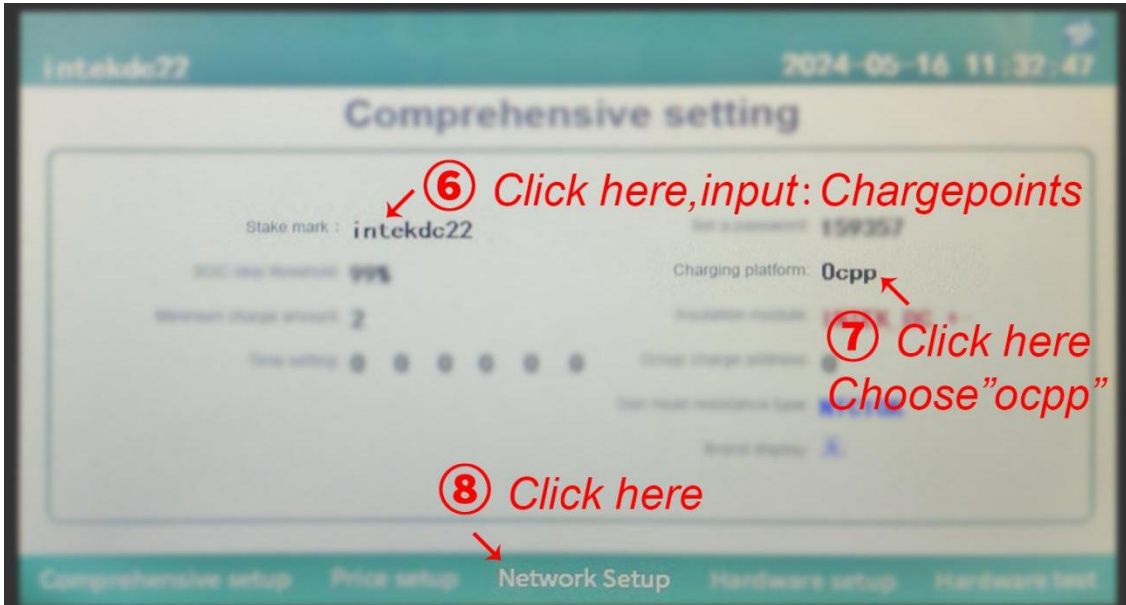

⑨ Click GPRS4G or ETH on the right of the screen, if it is already GPRS4G, no click;

⑩ Adjust OCPP Path: Chargepoints url to wss: // dev.optima.az: 8314 / OCPP / intekdc22, enter wss: // dev.optima. Az: 8314 / OCPP /, then confirm;

*** Note: Note the double character keys on the keyboard (upper and lower characters), need to use Caps Lock to switch; for example: ':' needs to use Caps lock to input, do not enter ','; click Caps Lock again to switch to normal state before entering letters and numbers.**

⑪ After returning to the interface, click the bottom left button of the screen to return to the comprehensive Settings interface, and then continue to click the bottom left button to return to the initial interface;

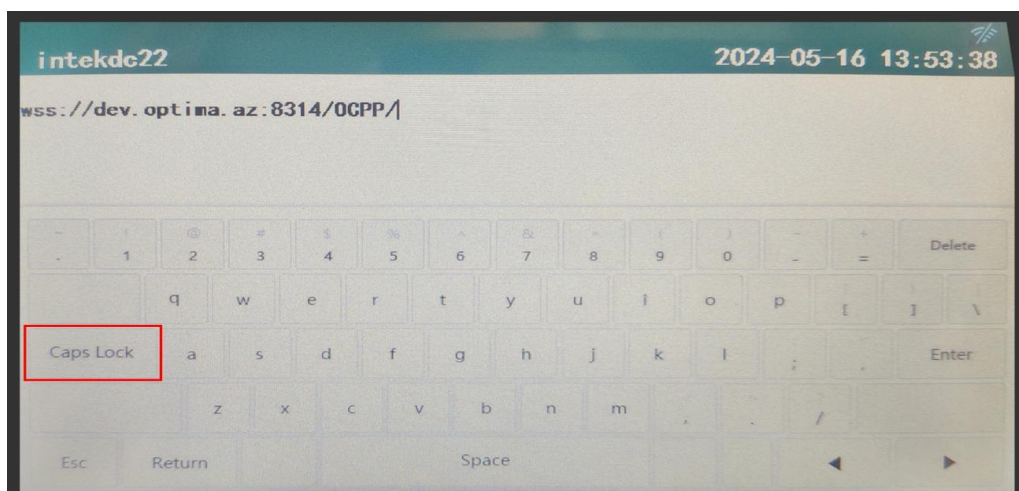

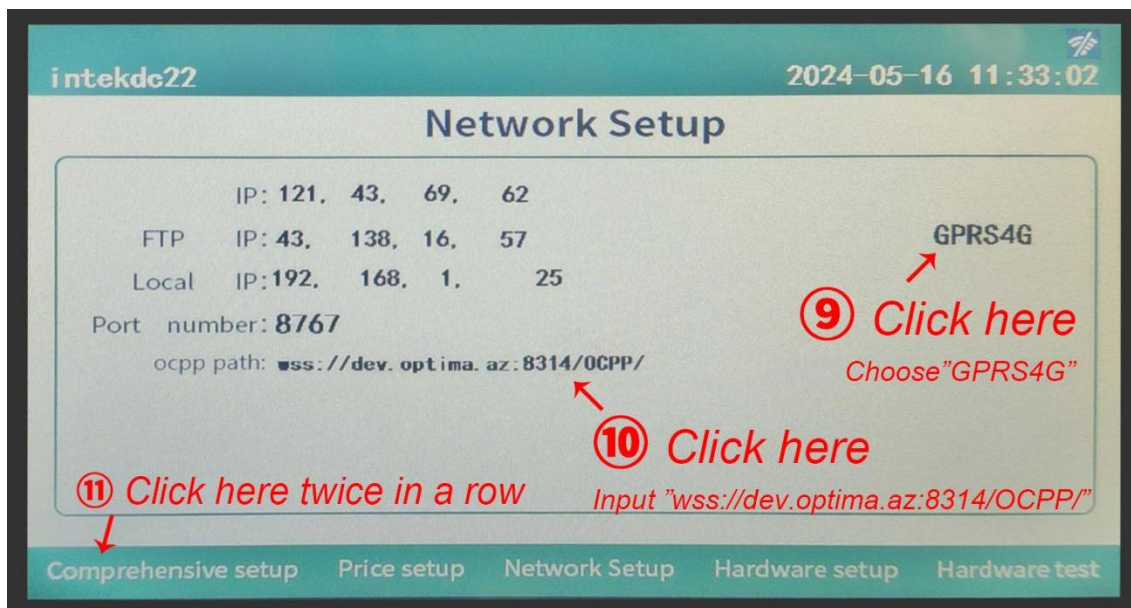

⑫ After returning to the initial interface, restart the charging pile and wait for 1~5 minutes, when the signal mark is displayed in the upper right corner of the screen, the communication is successful;

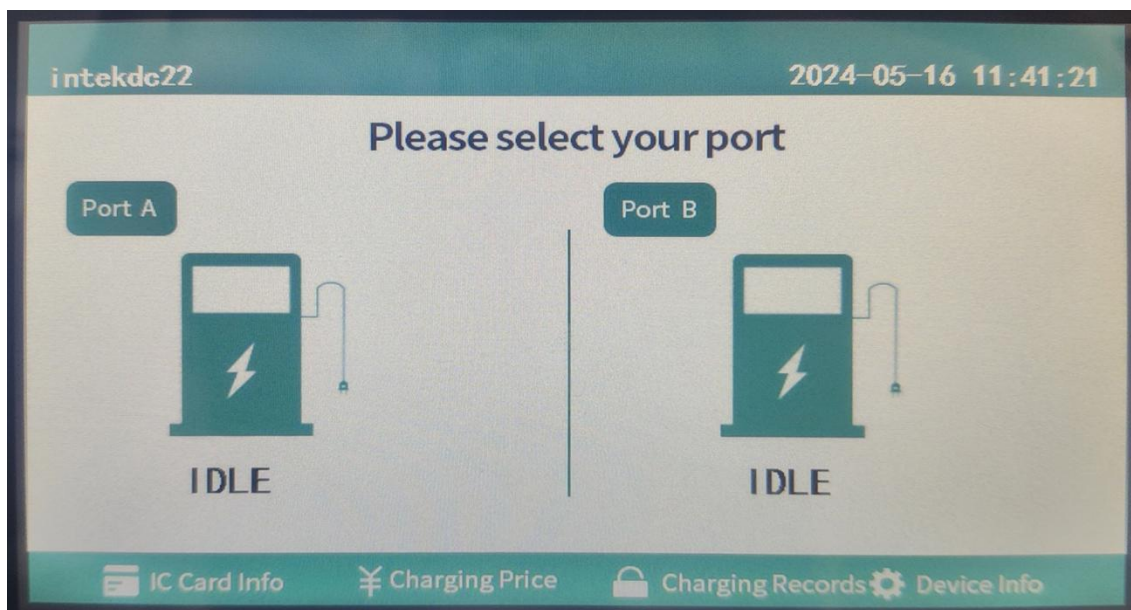

The following is The Setting Description of Ethernet Cable of Charger:

Insert the Ethernet network cable into the OCPP small board subnet cable slot (as shown below), the other steps are the same as the above SIM card mode, change the right side of the Network Setup interface to ETH;

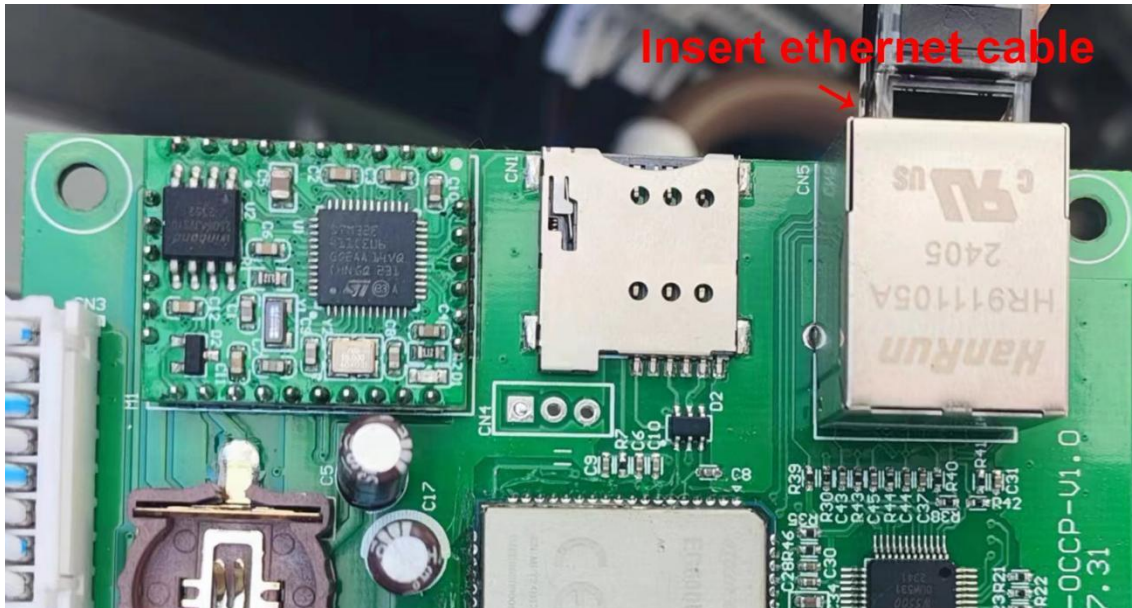

Click ETH on the right of the screen, if it is already ETH.

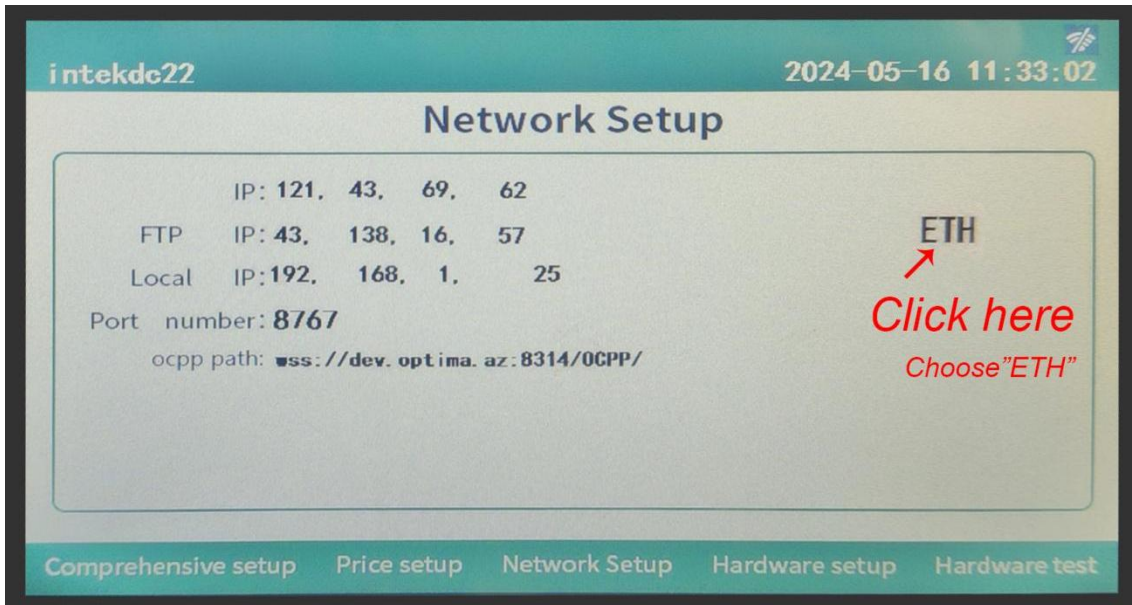

Then return to the original interface, restart and wait for its communication.

4.4 Operational Integration

- After startup, the charger connects with the cloud platform for remote management, diagnostics, and updates.
- For integration with customer's existing platforms, contact our sales or service engineer.

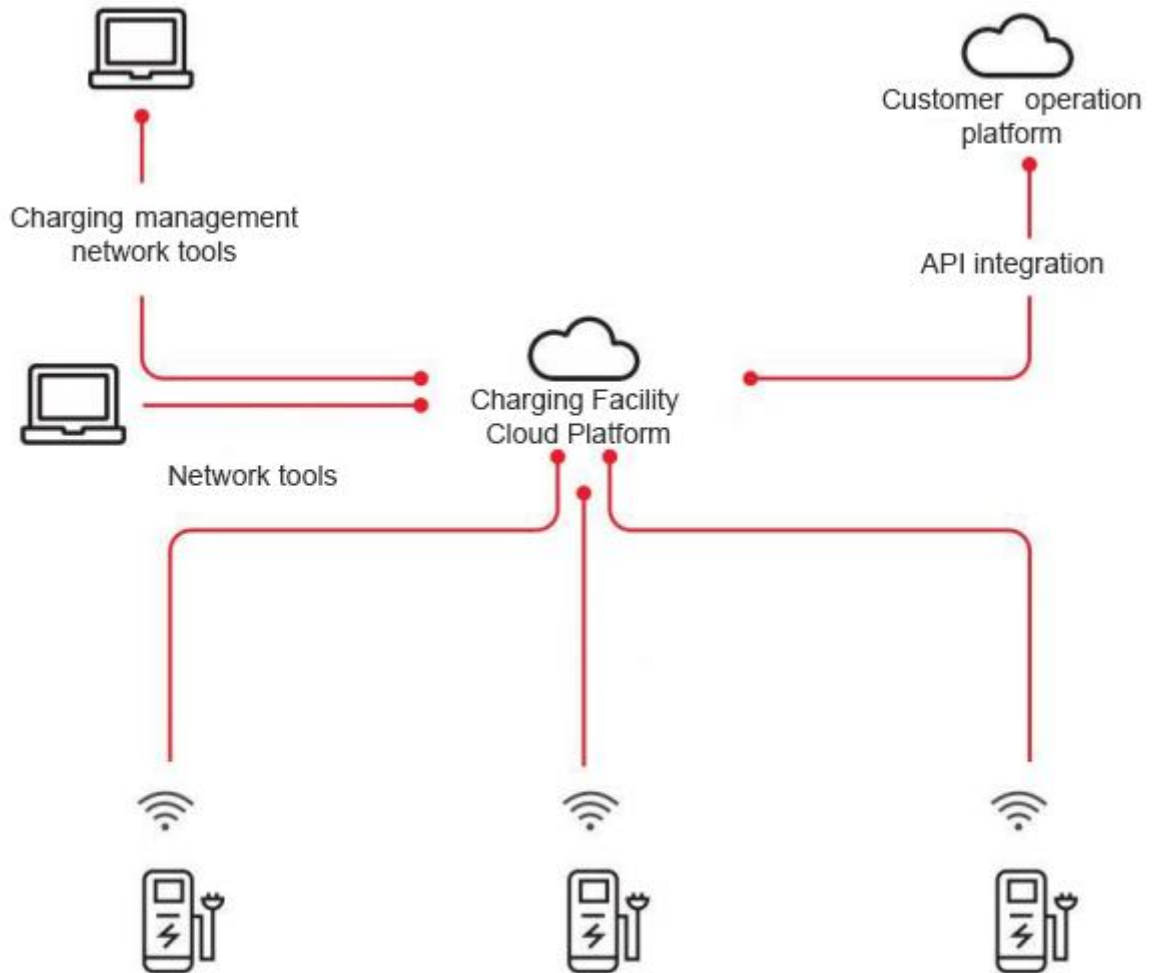

V.Maintenance Instruction

5.1 Daily Maintenance

Daily maintenance can keep the EV charger in a safe and stable and good state.

- Clean up the outer surface of the EV charger every two months
- Tighten the screw bolts at key parts every quarter
- Clean the air filter cotton and dust filter at least once every six months
- Test the leakage protection device once a year

Clean the Appearance

The outer surface of the EV charger is sprayed with powder, which needs to be kept in good state and maintain a beautiful image.

- Stop all the charging process, cut off the power supply, and plug in the charging connector
- Use wet, dust-free cloth to remove foreign matter and dust from the surface of the cabinet
- Only use strong stains with pH between 6 and 8, and then wash with clean water

Test the Electric Leakage Protection Device

Leakage protection are very important safety systems that are tested once a year. Do not test the leakage protection device during charging. Please stop all the charging processes before testing. Disconnect the EV charger from the vehicle.

- Open the front door and side door of the EV charger; when the cabinet door is opened, the EV charger will not be directly exposed to stormy weather.
- The EV charger must be in the standby state, and can be woken up by touching the screen.
- Click the Test test button for the leakage protection device.

-OK: the leakage protection device jumps to the "off" position and the EV charger stops running; by placing the switch in the "open" position, the device will start again.

-Bad: If there is no reaction when the test button is pressed, disconnect the AC power supply of the device and close the cabinet door; do not use the charger again until the leakage protection device is repaired, and contact our company or local supplier.

- Close the side doors and front doors of the EV charger.
- Note the time required to test the leakage protection device for each year.

Clean and Replace The Air Filter Cotton and Dust Filter

The EV charger is equipped with air filter cotton with a dense area of mesh to prevent the dust damage of electronic components. You need to clean the air filter and dust gauze at least once every six months:

- Always stop all charging processes before cleaning and replacement
- Open the side door of the EV charger; when the cabinet door is opened, the device shall not be directly

exposed to stormy weather.

- Unscrew the hand and remove the baffle and the original air filter
- Clean up debris or dust from filter and dust gauze
- Install the cleaned filter, and install the baffle and screws
- Close the side door



Pay Attention To

If the EV charger operates without the air dust filter , or the air dust filter is not replaced on time,it will damage the device and the resulting fault is not within the warranty range.

5.2 Maintenance and Maintenance

This equipment is an Internet of Things type EV charger, with intelligent functions such as pre-charging self-inspection, daily regular self-inspection, online monitoring of electrical parts and operating parameters.

When operation is normal, only daily maintenance is needed, no more further maintenance required.

When operation is abnormal, please refer to the following fault handling

VI. Fault Treatment

6.1 Fault Identification

The EV charger installed in open places may fail due to various reasons, which should be roughly identified:

Improper Use of Fault

- Emergency stop button pressed
- Forced connector pulled

Charging System Failure

- See the list in the "Processing Methods" later

Electric Vehicle System Failure

- Abnormal system faults, abnormal voltage, abnormal insulation and other faults of electric vehicles will

lead to charging failures.

Man-made Fault Destruction

- the charging connector to crack, press, soak water
- The charging cable is rolled over and pulled by the wheel
- The charging cable is pulled and broken by the external force
- the EV charger is hit by a driving vehicle or a heavy object
- The door of the EV charger cabinet is opened abnormally
- Air duct blockage, etc

Note, human damage failure is not within the scope of warranty service

Natural Disaster Failure

- the earthquake damage
- Heavy rain flooding
- Lightning disaster
- An external fire

Note, the natural disaster failure is not within the scope of the warranty service

6.2 Treatment Method

Order Number	Display Status	Possible Cause	Suggest How to Deal With	Preliminary Treatment Party
1	Black screen, all the touch can not be lit	The AC input of the charging pile is dead	Check whether the input power supply of the charging pile is normal: the parent flow two-phase input voltage per phase is about 220V, and the line voltage is about 380V. Whether the input cable has any leakage, short circuit situation. If the input is normal, please try to restart. If the fault is still not resolved, please contact our service personnel	Customer operation and maintenance/ The company service
2	Screen Flickering, white screen, can not correctly display the information	The EV charger runs for 24 hours continuously, and the display screen dies, rarely appearing	Try to restart the power. If the fault is still not resolved, please contact our service personnel for handling	Customer operation and maintenance/ The company service
3	Display: insulation detection fault	Insulation fault of the vehicle or EV charger	It is suggested to replace a EV charger for charging. If the problem is similar, it is the problem of the car. If there is no fault, it is a EV charger problem, please contact the service personnel of our company for further processing	User/ The company service
4	Other issues not involved above	There are many possible reasons why it is not easy to determine	Please contact our service personnel for handling	The company service

6.3 Maintenance Records

Order	Fault Phenomenon	Maintenance	Result of	Attendant	Date	User
1						
2						
3						
4						
5						
6						
7						
8						

The above forms are used for maintenance records.

User Name (Company / Mr. / Ms.):

contact number:

installation time:

VII.After-sale Service

When the product is unusable, you can contact us through the local operator. we will then arrange for professional engineers to provide remote guidance until the problem is solved. You can also express your needs via email, and we will promptly provide you with the necessary services.



Email address: heshiyu.1988@163.com



160kW DC CHARGING

Installation and User Manual

Thank you for choosing our DC charging station product. To help you install and use the charging station correctly, please read this manual carefully and keep it safe. If you still have any questions about any of the contents, please contact our company in a timely manner and seek help. Our company reserves the right to modify the technical features and content in this manual.



















CATALOGUE

I. Security Statement	- 1 -
1.1 Safety Identification	- 1 -
1.2 Safety Warning	- 2 -
1.3 Liability Statement	- 2 -
II. Product Overview	- 4 -
2.1 Product Parameters	- 4 -
2.2 Functional Features	- 5 -
2.3 Product Description	- 7 -
III. Installation Instructions	- 11 -
3.1 Construction Preparation	- 11 -
3.2 Installation and Preparation	- 13 -
3.3 Installation Steps	- 16 -
3.4 Installation and Adjustment	- 21 -
IV. Direction for Use	- 22 -
4.1 System Startup	- 22 -
4.2 Charging Operation	- 23 -
4.3 OCPP Network Settings	- 28 -
4.4 Operational Integration	- 33 -
V. Maintenance Instruction	- 34 -
5.1 Daily Maintenance	- 34 -
5.2 Maintenance and Maintenance	- 35 -
VI. Fault Treatment	- 36 -
6.1 Fault Identification	- 36 -
6.2 Treatment Method	- 37 -
6.3 Maintenance Records	- 38 -
VII. After-sale Service	- 39 -

I.Security Statement

1.1 Safety Identification

	<p>Refer to Instruction Manual</p> <p>It typically signifies that user guide manuals or original documents must be kept properly for future use, and must not be damaged in any way</p>
	<p>General Warning</p> <p>Important security information that must be very carefully observed</p>
	<p>Dangerous Voltage</p> <p>Indicates situations where dangerous voltage must be handled with extreme caution</p>
	<p>High Temperature Warning</p> <p>Represents the burn hazard in high temperature areas or areas with high component temperatures</p>
	<p>Hazard of Injury Due to Equipment Weight.</p> <p>Indicates careful lifting and transport are required to avoid injury</p>
	<p>Prohibition Notice</p> <p>It means that entering the relevant area or performing the operations is prohibited</p>
	<p>Avoid Child Contact</p> <p>Indicates that the equipment should be kept out of reach of children</p>
	<p>No Smoking and Using Open Fires are Allowed</p> <p>Indicates prohibition of smoking and use of open flames near the equipment</p>
	<p>Personal Protective Equipment</p> <p>Indicates that the operations must be performed using clothing and / or personal protective equipment provided by the employer</p>
	<p>Ground Protection Connection Point</p> <p>Indicates the designated connection point for ground protection</p>
	<p>Allowable Temperature Range</p> <p>Indicates the range of temperatures within which the equipment can operate safely</p>
	<p>Direct Current</p> <p>Indicates the use of direct current(DC)</p>
	<p>Alternating Current</p> <p>Indicates the use of alternating current(AC)</p>
	<p>Positive Electrode of the Input Voltage</p> <p>Indicates the positive electrode for input voltage/current</p>
	<p>Negative Electrode of the Input Voltage</p> <p>Indicates the negative electrode for input voltage/current</p>
	<p>Note Content Identification Suggestions or Comments</p> <p>Indicates notes or suggestions for the content</p>

1.2 Safety Warning

The company's EV Chargers are designed and tested in strict accordance with the relevant national and international safety standards. However, the safety of power electronic equipment is not only affected by the quality of the equipment itself, but also highly related to handling, installation, trial operation, operation, maintenance, demolition and other operations. Incorrect use or misoperation will lead to the following risks:

- Risks of electric shock, short circuit, fire, explosion, and severe burns;
- Harm to the life and personal safety of the operator or a third party;
- Damage to the EV Charger or other property.

To avoid safety accidents, the following safety precautions should be strictly observed during installation and maintenance.

- All preparation, installation, movement, maintenance and disassembly, must be completed by professional and technical personnel. Unauthorized loading and unloading are prohibited.
- Professional and technical personnel must be qualified and trained or proven to have skills and knowledge in the structure and operation of EV Chargers;
- Read this manual completely and understand the relevant safety matters.

1.3 Liability Statement

Owner Responsibility

Requirements for Charging station owners and field operators:

- Run the charging station with full implementation of protective measures ensuring the correct installation and regular maintenance of protective facilities;
- Prepare an emergency plan to handle emergencies effectively;
- Prepare the installation site according to the requirements described in this manual;
- Ensure sufficient space for passage and maintenance of the EV Chargers;
- Assign a person responsible for safe operation and overall coordination;
- Understanding that unauthorized changes can affect the operation authorization or warranty.

Disclaimer

The Company shall not be liable for accidents or damage caused by:

- Human factors or abnormal working environments;
- Faults and damage caused by not following the instructions;
- Damage due to poor transport after delivery;
- Normal wear and tear, rupture and immersion dyeing;

- Products not belonging to the company (eg: counterfeit goods);
- Unauthorized disassembly, repair, or modification
- Damage due to other non-resistance (such as flood, fire, lightning strike, typhoon, earthquake, abnormal voltage);
- Use beyond the service life not covered by warranty;

II.Product Overview

2.1 Product Parameters

No.	Product	Dc Charger For Electric Vehicles
1	Input Line System	Three-phase five-wire 3P + N + PE
2	Input Voltage	380V/400V AC \pm 20%, 50Hz/60HZ
3	Rated Power	160kW DC
4	Power Factor	\sim 0.99 (Full load)
5	Output Voltage	200—1000VDC
6	Constant Power Area	300—1000VDC
7	Maximum Current of Single Connector	250A DC
8	Cabinet Dimensions	800mm*630mm*1830mm (excluding Connector holder)
9	Levels of Protection	IP54
10	The charging Cable Length	5m
11	Noise	\leq 75dB
12	Working Temperature	-20 $^{\circ}$ C \sim +50 $^{\circ}$ C
13	Storage Temperature	-20 $^{\circ}$ C \sim +70 $^{\circ}$ C
14	Working Humidity	Relative humidity 5% to 95%
15	Working Altitude	Up to 2000m (above 2000m needs special consideration)
16	Gas Medium	Should avoid explosive, corrosive and harmful gases and conductive media
17	Open Installation	Suitable for all-weather open-air installation
18	Verticality	Mounting vertical inclination should not exceed 5 $^{\circ}$
19	Cable Entry	Bottom entry for cables
20	Cable Outlet	The upper cable outlet of the cabinet is designed to be waterproof and resistant to immersion, rain, and snow. It also prevents tripping hazards for pedestrians and vehicles.

2.2 Functional Features

Safety

- Unique safety mechanisms including pre-charging protection, main circuit safety detection and remote diagnosis management
- Basic protection measures such as lightning protection, overvoltage, overcurrent, short circuit, connection fault, and emergency stop
- Comprehensive charging protection functions and mechanisms that effectively guarantee the safety of personnel, prevent overcharging, and ensure operational safety

Intelligence

- The terminal EV Chargers and the cloud platform intelligent Internet of Things can perceive more than 100 underlying operating parameters in real time
- Features remote diagnosis, remote reset, and remote upgrade capabilities.

Reliability

- Independently designed hardware and software, from circuit boards to system architecture, and from embedded software to cloud platform, ensuring high consistency, compatibility and stability
- Performance Metrics such as current accuracy, voltage accuracy, leakage protection accuracy, ripple harmonic, and standby power consumption exceed industry averages.
- Utilizes international first -line brand components for high system reliability. The wind duct maze design effectively prevents issues such as splashes and accidental collisions, making it suitable for installation in urban public parking lots and roadside parking spaces.

Convenience

- Flexible networking options with both wireless and wired communication modes.
- Anti-sunlight liquid crystal display with a user-friendly interactive interface
- Open communication protocol supporting code scanning charging, API services, and energy demand response

Interactive Function

- All charging stages include intuitive and friendly illustrations and text prompts on the screen.
- The screen features an anti-sunlight display and is ergonomically arranged for ease of use.

Measurement function

- DC metering function with an accuracy level of 1.0.

Communication Function

- Supports Ethernet access and 4G wireless communication networking.

Payment Function

➤ The EV Charger provides charging consumption time and quantity information to the operation background which centrally controls the charging strategy. The integrated system supports various payment methods such as card swiping, code scanning, and mobile app payments.

- Customizable optional POS machine supporting VISA and international credit card payments.

Self-Test and Self-Repair Function

➤ During power operation, the EV Chargers conducts a self-check of the equipment's working environment, power supply, data storage space.

➤ Fault information is displayed on the screen, recorded, and stored in the superior monitoring and management system.

➤ Automatically monitors the operation of key components, including but not limited to charging connectors connection self-test, contactor adhesion self-test, and power unit state self-test.

Remote Internet of Things Function

➤ The EV Chargers connects with the device cloud platform to monitor numerous parameters in real time providing comprehensive remote diagnosis, remote service, and remote upgrade service

Diagnostics include checks for whether the charger cabinet door is opened, whether the emergency stop button is pressed, whether the AC contactor is disconnected, whether the vehicle is connected, whether the connector head temperature is too high, and whether the insulation test is normal.

2.3 Product Description

Product Appearance



A.LED Indicator Light

B.User Interface Display Screen

C.POS Machine (Configuration Options)

D.Emergency Stop Button

E.Cabinet Lock

F.Charging Cable

Note: Due to the version iteration, there may be some differences between photos and physical objects.

Inner Structure

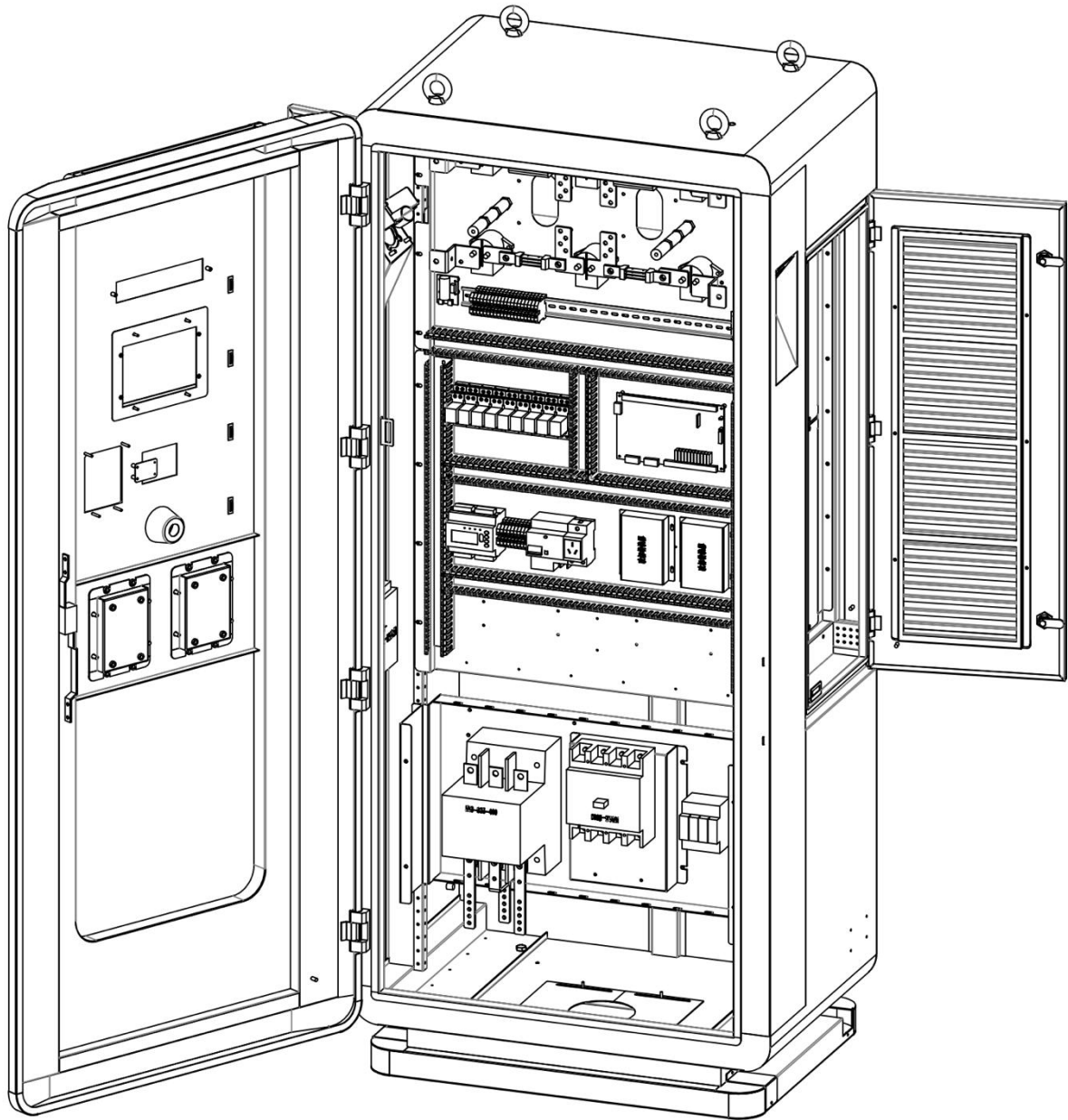

Note: Due to the version iteration, there may be some differences between photos and physical objects.

Space Requirement

To ensure the safe and reliable operation and convenient maintenance of the equipment, sufficient space for installation must be reserved.

The space requirement during installation is 1800mm * 1680mm, calculated as follows:

- **Dimensions(W * D * H):** 800mm * 630mm * 1830mm (excluding connector holder)
- **Front Side Clearance:** Reserve 1000mm to ensure the normal operation of the front door switch and smooth functioning.
- **Left Side Clearance:** Reserve 500mm to allow for normal operation of the front door and smooth functioning.
- **Right Side Clearance:** Reserve 500mm to enable normal operation of the side door , maintenance space for the charging module, and smooth airflow into the air inlet.
- **Rear Clearance:** Reserve 50mm to ensure that the side doors on both the left and right are not obstructed.

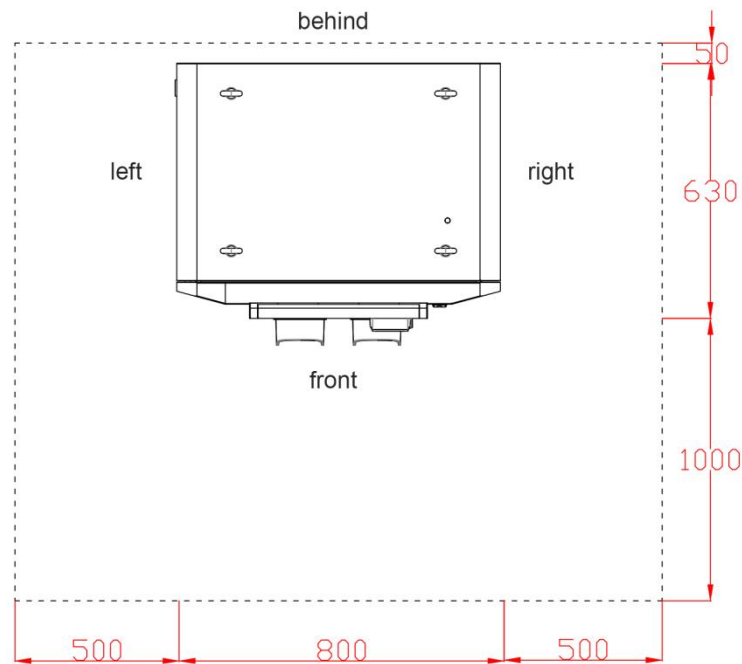

Ventilation Requirements

The EV Chargers converts AC to DC to charge electric vehicles. During this conversion process, some energy is lost as heat, necessitating efficient heat dissipation. Therefore, it is essential to ensure that the installation space has open and continuous airflow, and that the main air inlet and outlet paths are not blocked. It is not recommended to install the charger in a confined space without ventilation. The product's air inlet is located on the right side of the screen, and the air outlet is on the left side.



Attention

Ensure Unobstructed Airflow:

Preventative measures should be taken to keep the air ducts clear.

Avoid any obstructions, such as snow or foreign objects, from blocking the air inlet and outlet.

III. Installation Instructions

3.1 Construction Preparation

About the Construction

The construction phase includes all tasks necessary to prepare the installation site for placing and connecting the EV charger. The following conditions must be met to begin the construction phase:

- All engineering preparations are complete
- All necessary permits have been obtained
- The grid can be connected

Cable Entry

The cable should enter through the bottom of the EV charger.

Infrastructure Projects

The suitability of the installation site is related to the surface type of the infrastructure construction.

Foundation Requirements

-Indoor Installation: A foundation is not required if the equipment is installed indoors or in other high and dry places. The ground smoothness error must not exceed $\pm 1.5\text{mm}$ per square meter, and the ground strength at the installation position should be at least C30.

-Outdoor Installation: When installed outdoors or in areas prone to water accumulation, a cement or tank steel base must be used. The cement base should be 200mm high, with a recommended depth below ground of at least 500mm. Four M12 stainless steel bolts should be embedded in the installation surface, extending $40 \pm 3\text{mm}$ above the ground. The foundation design should be tailored to the actual site conditions.

-Instructions:

- Excavate a pit at the installation site as specified.
- Ensure the cable can enter through the embedded pipe, with an aperture of at least 100mm.
- Pour the concrete foundation as illustrated.
- Ensure the EV charger's base height is at least 200mm to reduce flooding risk.
- Expose 0.7m of cable length above the foundation for internal wiring.

Fill the foundation's inner and outer holes with sand and stone, and seal the inlet holes with fireproof mud to prevent small animals from entering the equipment.

Base Hole Position and Installation Method

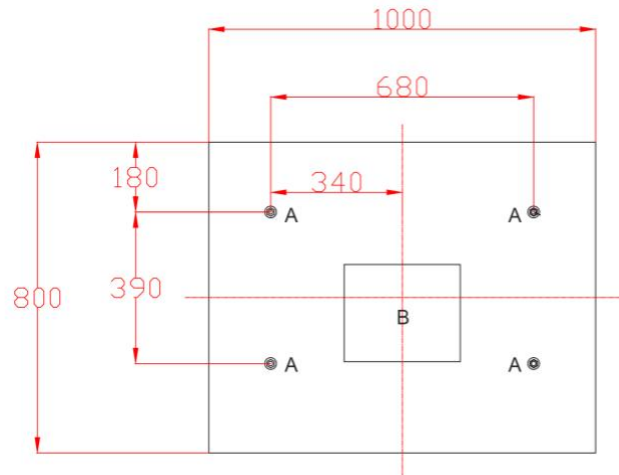

- Figure A: Embed four M12 stainless steel bolts.(screw anchor)
- Figure B: Identify the power cable entrance location.
- Exposed cable length for internal wiring is 0.7M

Cable Protection Requirements

- **Cable Type:** three-phase and five-wire system (3P + N + PE),
Verify if shielding is required based on local laws.
- **Shielding Layer:** Connect both ends of the shielding network with the PE safety ground wire if present.
- **Cable Diameter:** Determined by the contractor or electrical engineer based on power, distance, and industry standards.

- **PE Safety Ground Wire:** Should match the N wire model size.

- **Recommended Cable Cross-sectional Area:**

-For 120kW: YJV 4 * 95 + 1 * 50

-For 160kW: YJV 4 * 120 + 1 * 70

- The cable must comply with national and local standards.

- Each EV charger must have independent open and leakage protection.

Network Connection Requirements

-**Standard:** 4G wireless communication module integrated with the EV charger. Users should prepare a SIM card. If no 4G signal is available, use a standard wired Internet connection.

-Wired Connection Requirements:

--**The RJ 45 Ethernet:** 8P + PE, shielding wire.

-- **Recommended Length:**

Up to 75m, refer to HELUKAT 600E.

For lengths over 75m, an engineering scheme is required.

--The Minimum Bandwidth:

Uplink: 128 kbps

Downlink: 4 Mbps

--Connection Dependability: 99.9%

3.2 Installation and Preparation

Transport Loading and Unloading

- Handle heavy equipment with care.
- Use appropriate load-bearing equipment such as forklifts, cranes, or towing trucks, operated by professionals.
- Avoid dumping or crashing the equipment.

Keep the device upright, with a tilt angle not exceeding 30 degrees.

Arrival Inspection:

- Check for package damage and label correctness upon arrival. If any abnormality is found, inform the carrier, take photos, and collect evidence. Sign the documents and contact the manufacturer for further action.
- Verify that product accessories and accompanying documents are complete according to the packing list.
- Inspect the product visually for any signs of collision, scratches, cracks, corrosion, damage, or paint peeling.
- Check the charging connector for any abnormalities such as crushing, rust, damage, or loose connections.
- Sign documents, save records, and distribute or transfer them to related parties.

On-site Confirmation

- Ensure that the site's altitude, coordinates, temperature, humidity, ventilation, load-bearing capacity, installation position, maintenance space, and power supply meet the equipment's requirements.
- Confirm that the on-site 4G signal strength is good (signal strength greater than -85 dBm, or above 50% full grid strength as observed on a mobile phone).
- Verify that all necessary licenses are in place.
- Confirm that the project preparation work is complete and the power grid connection is available.
- Avoid starting installation if construction is ongoing at the site to prevent damage from building

materials, dust, paint, muck, or litter. It is recommended to install the EVcharger after construction is completed.

For short-term or long-term storage, store the equipment in a dry, well-ventilated indoor place, away from high temperatures, humidity, dust, metal powder, and corrosive gases.

Important Notes:

➤ Due to the complexity and danger of EV charger installation, only qualified professional and technical personnel should perform the installation according to this manual.

➤ Prepare and check relevant tools and devices, ensure personal protection, and wear protective gloves during installation to prevent injuries from metal parts. Use appropriate lighting devices if needed.

➤ Ensure all switches associated with the equipment are in the off state (when repairing or replacing spare parts, ensure the equipment is well grounded).

Use professional tools to confirm the power supply is disconnected, with no power input and output to the equipment. Ensure each charger has independent protection and disconnection conditions, and use a special power interface with proper grounding. Fire and neutral wires must not meet. Turn off the power and take reasonable measures to prevent the power switch from closing automatically.

Installation Tools

Name	Main Role	Quantity
Multimeter	Check Electrical Connections and Parameters	1 pc
Electric Impact Drill	Drill Holes	1 pc
Impact Bit (Φ 16mm)	Drill Bit	2 pcs
Band Tape	Measure	1 pc
Leveling Instrument	Measure	1 pc
Slotted Screwdriver	Open	1 pc
Plier	Open	1 pc
Wire Stripper	Remove Insulation Sheath	1 pc
Terminal Crimping Pliers	Crimp Terminals	1 pc
Diagonal Pliers	Cut Cables	1 pc
Adz-eye Hammer	Unpack, Tap and Adjust	1 pc
Transport Equipment	Move and Hoist EV Chargers	1 set
PVC Insulation Tape	Insulate Connections	1 roll
Personal Protection Tools	Ensure Operator Safety and Health	1 set/ personnel
Multi-Function Crowbar	Remove Wooden Box	1 pc

Basic Tools

Order Number	Nut /Bolt	Tool	Installation Site
1	M12 Hexagon Nut	19 # Tools Included With The Charger	Base Installation (fixed to cement base)
2	M8 Inner Hexagon Bolt	6mm Inner Hexagon Spanner	Input Ground Wire, ABC Phase Power Input, N Wire Installation
3	M10 Inner Hexagon Bolt	8mm Inner Hexagon Spanner	160kW Cable, ABC Phase Power Input, N Wire Installation

Installation, Repair, and Replacement of Spare Parts

Safety Precautions:

- Live work is strictly prohibited
- Unauthorized disassembly is strictly prohibited.
- Ensure equipment operation safety.
- Follow the sequence PE ground wire > zero wire > phase wire for power supply line access.
- All operations must comply with the relevant safety standards

Post-installation, Repair, and Replacement

- Perform acceptance and testing according to installation and maintenance requirements.
- Organize and collect tools, restore the internal switch to the working state.
- Lock the safety door to maintain equipment safety.

3.3 Installation Steps

Receiving the Goods

EV charger products can be delivered by the transportation company to the destination warehouse or the agreed location. For standard orders, the factory is not responsible for delivering the equipment to the final installation point. Prepare personnel and equipment for unloading and transfer at the receiving site.

Removing the Packaging

Use a multi-functional crowbar to remove the outer packaging, and use scissors or an art knife to remove the inner packaging.

Installation Preparation

- Open the side cover plate of the base, release the clamp cylinder, open the stack plate screw, etc.
- Unscrew and keep the screws on the base side cover plate.
- Remove and safely store the side cover plates and the front door of the EV charger.
- Open the front door of the EV charger
- Check for any abnormalities such as loose threads or parts.
- Reattach the side door and front door in sequence.
- Unclip the bolts securing the cabinet to the stack plate.

Placing the Equipment in Position

Move the equipment to the pre-made concrete base using one of two methods:

- 1: Lift the EV charger into position using optional lifting rings.
- 2: Use a lifting forklift to carry the EV charger into place.



High Voltage Safety

Ensure that the main and auxiliary circuit switches of the EV charger are disconnected. Perform voltage detection to confirm no current is present in the wires and system.



Warning

Handling the EV charger after delivery is not covered under warranty. Handle with care during transportation and installation.

Handling EV Charger

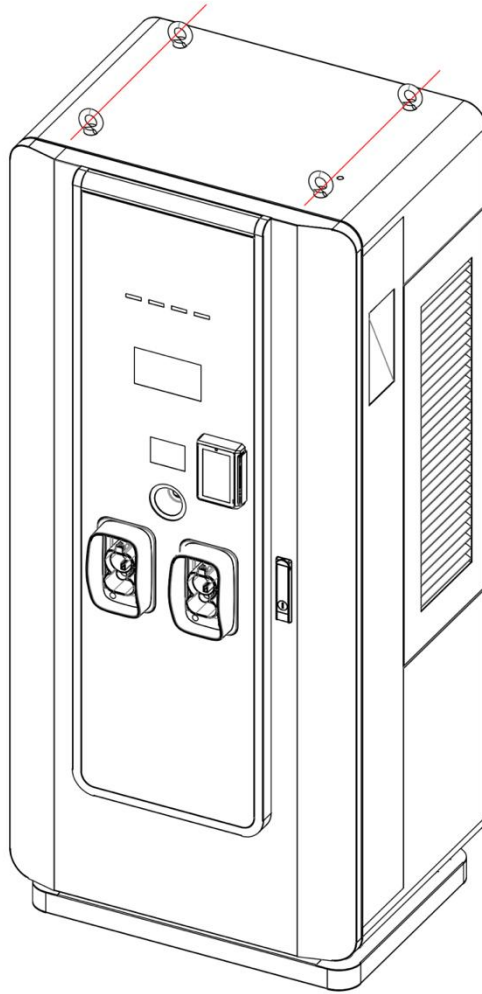

- Open the base-side cover plate
- Use the forklift truck to pass through the designated red line position as shown
- Carefully move the EV charger to the installation position

Locking the equipment

Preparation

- Tool: 19# wrench (for fixing M12 hexagon nuts).
- Raise the EV charger by about 0.5m and place it above the installation position.
- Pass the traction power cord through the cable envelope.

Placing the Cabinet to the Base

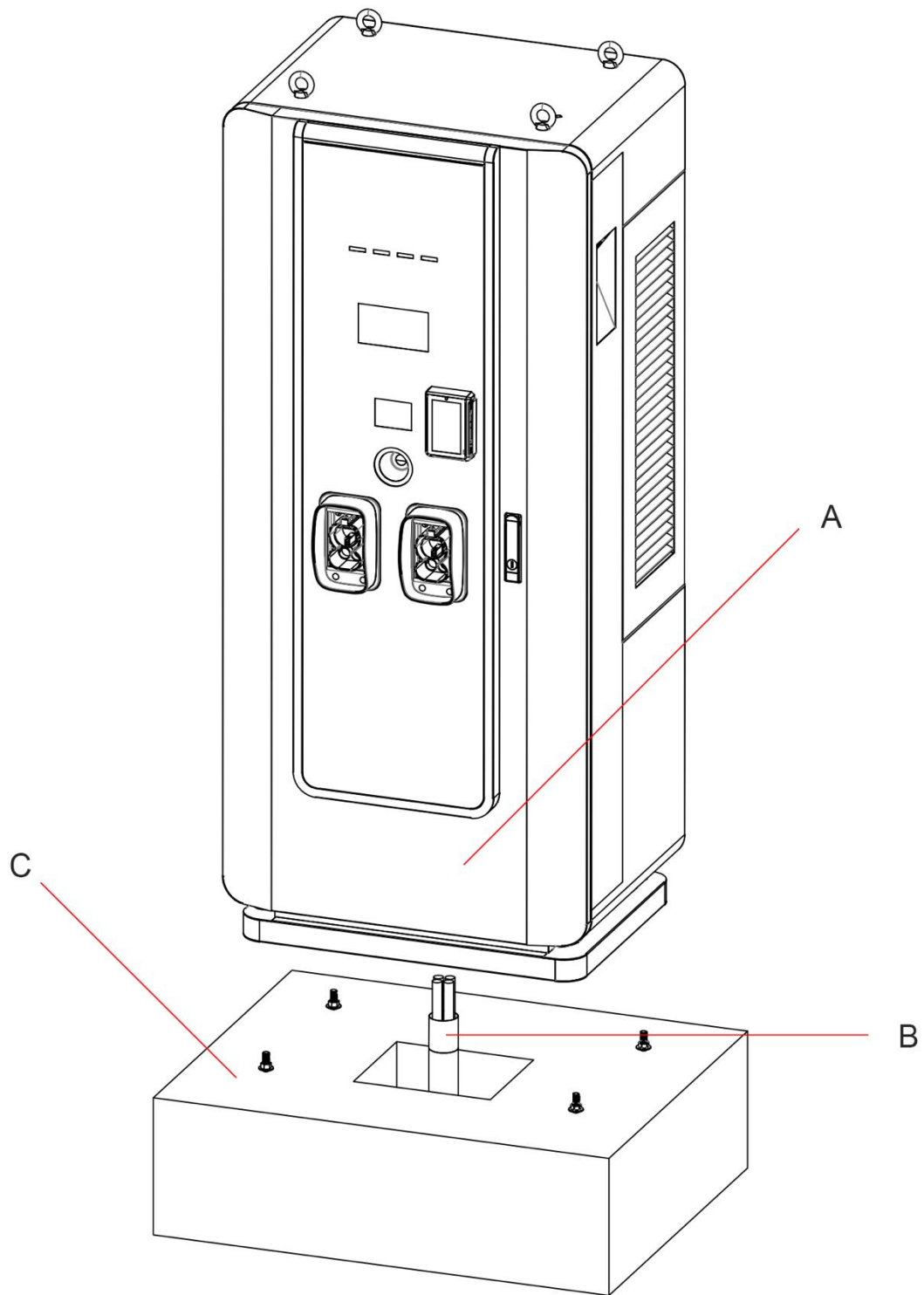

A. EV Charger

B. Cable

C. Concrete Pedestal

Placing the Cabinet to The Base

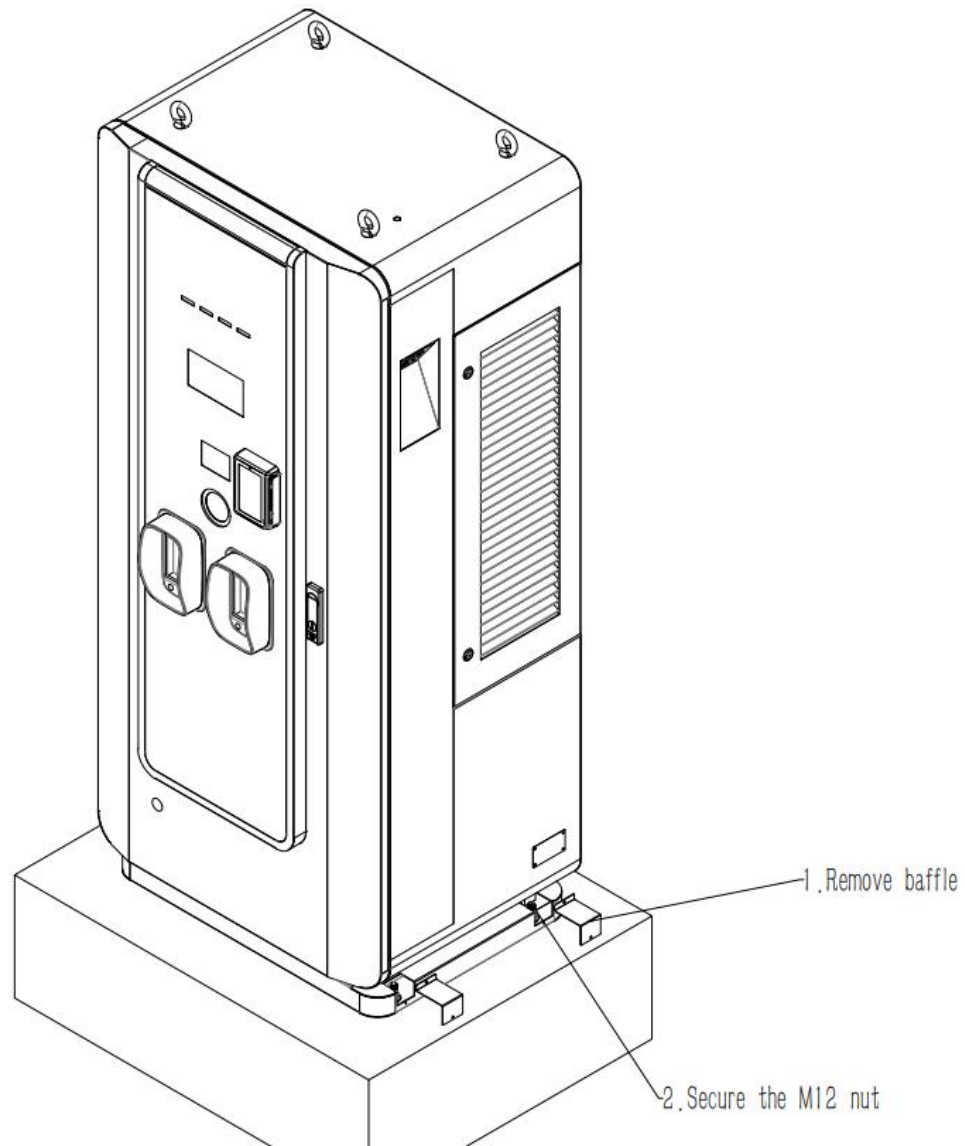

- Slowly lower the EV charger into place.
- Ensure the cable is exposed inside the cabinet along the envelope
- Align the cabinet holes with the bolt holes.
- Insert flat washers, spring gaskets, and M12 nuts.
- Tighten the nuts with a torque of 95.5Nm.

Connecting the Cable

Description: Different configuration versions require different wiring modes.

The reserved cable length is 0.7m.

- **Tools:** wire cutters, terminal / copper nose, terminal pressing clamp
- Remove 20mm of insulation at the cable end with a wire stripper.
- Crimp the cable end with suitable SC copper terminals.
- Connect the cable to the designated area as shown:
A/B/C for phase wire, N for neutral wire, PE for ground wire.
- The PE position is in the ground wire row at the bottom of the EV charger.
- Tighten the screws to a torque of 5Nm.

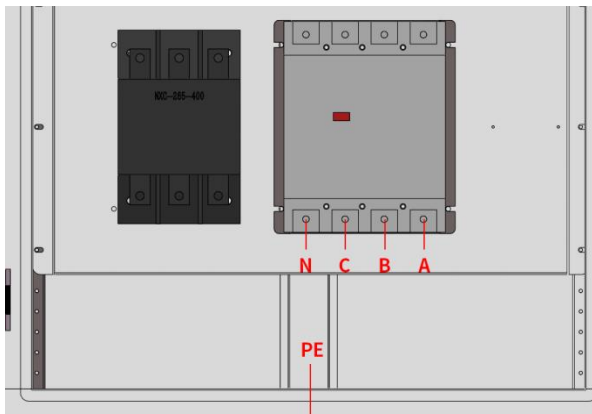

High Voltage Safety

Ensure that the main and auxiliary circuit switches of the EV charger are disconnected. Perform voltage detection to confirm no current is present in the wires and system.



Safety Note

For safety, it is recommended that the PE ground wire be left longer than the general phase wire to ensure the PE ground wire is connected first and disconnected last in case of an accidental collision.

Connecting Ethernet Cables

- **Tools:** network wire pressure clamp, RJ 45 connector, network cable
- **Procedure:**
 - Cut the network cable to the appropriate length for connection to the Ethernet interface.
 - Use the cable clamp to crimp the RJ 45 connector to the cable.
 - Connect the RJ 45 connector to the Ethernet interface.



Note:

This step is required only if the 4G network signal is poor or unavailable.

3.4 Installation and Adjustment

Installation and debugging are necessary final stages before the EV charger enters operation. The purpose is to check the safety and performance of the charging system for operational purposes.

Before Commissioning:

- Ensure all preparation, construction, installation, and connection tasks are completed.
- Connect the EV charger's input power supply and ensure the power charging capacity is ready.
- Assign a local project team technician for on-site assistance and power-on operation.
- Prepare a network cable connection if there is no 4G signal.
- Prepare a European standard pure electric vehicle for on-site trial charging tests.
- Arrange operation representatives for on-site guidance on charging operations.



Note:

The EV charger cannot be moved after debugging without negotiation.

Unauthorized movement voids the warranty.

For reinstallation to a new location, please contact our services in advance.

Once commissioned and verified, the EV charger can be put into operation.

IV.Direction for Use

4.1 System Startup

First Startup:

Execution by our professional or authorized personnel is required. For the first startup after installation in a new location, confirm that preparations are complete according to the "Installation Instructions". Contact the service engineer at least one week in advance to schedule installation, commissioning, and the on-site acceptance test (SAT). Do not complete the installation without performing the SAT.

Normal Startup:

Under normal conditions, connect the power supply, turn on the system power switch, and start the charging cabinet.



Caution:

- Do not touch the contact parts of the charging connector or immerse them in liquid to prevent electric shock.
- Do not place any objects in the charging connector or immerse it in liquid.
- Do not use the charger if there is any foreign object in the charging connector or if the contact is corroded or damaged.

4.2 Charging Operation

- Ensure the screen displays normally with no fault messages.
- Verify that the charger and its surroundings are in normal condition.
- If the screen displays any fault messages, do not use the charger and contact customer service for assistance.

Welcome Screen

System Initialization:

- Turn on the system power. The system will initialize upon startup.
- After initialization, the interface will display port status information.

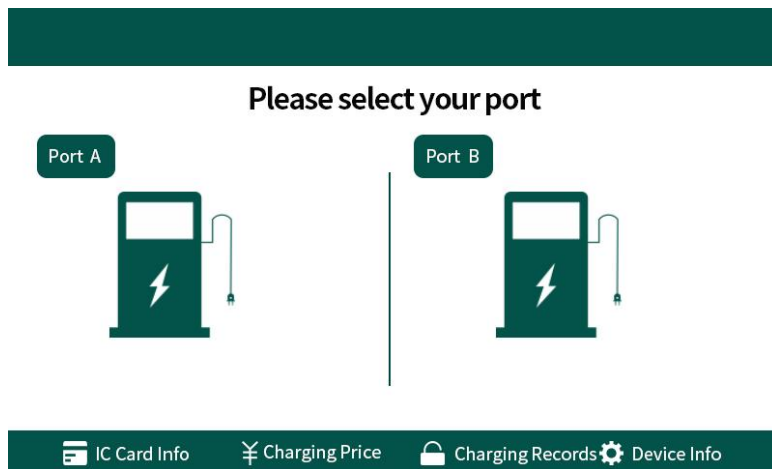

Port Selection

- Click the port labeled "Connected" to access the "Select Charging Method" screen.

As shown in the figure below:

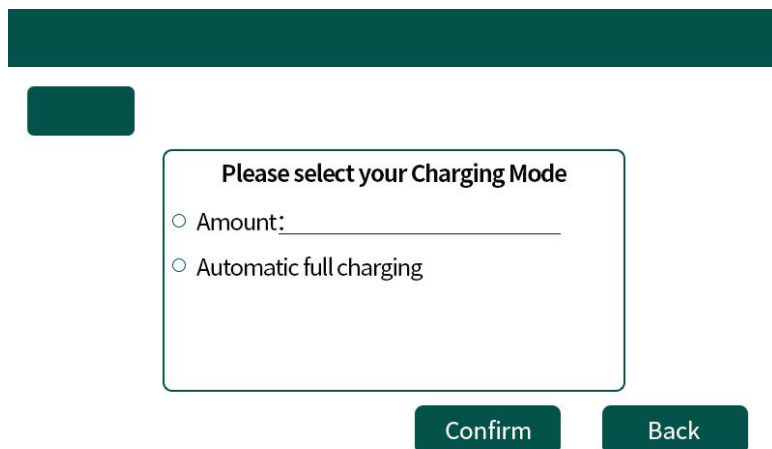

Swipe Card Charging

In the “Select Charging Method” screen, you can:

- Enter the desired amount and swipe a VISA or credit card on the POS terminal to start charging.
- Alternatively, click “Auto Full” and swipe the card to start charging.
- If the POS terminal is not configured, use the charging card provided by our company and swipe it in the designated area on the charger.

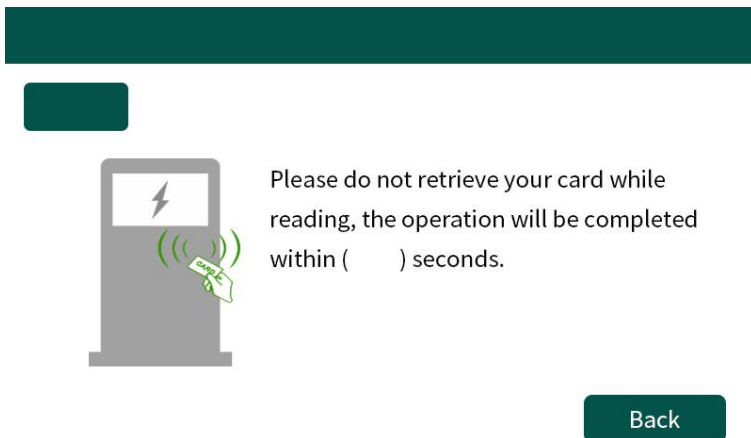

Scan Code Charging:

- Follow the on-screen instructions to scan the code and initiate charging.

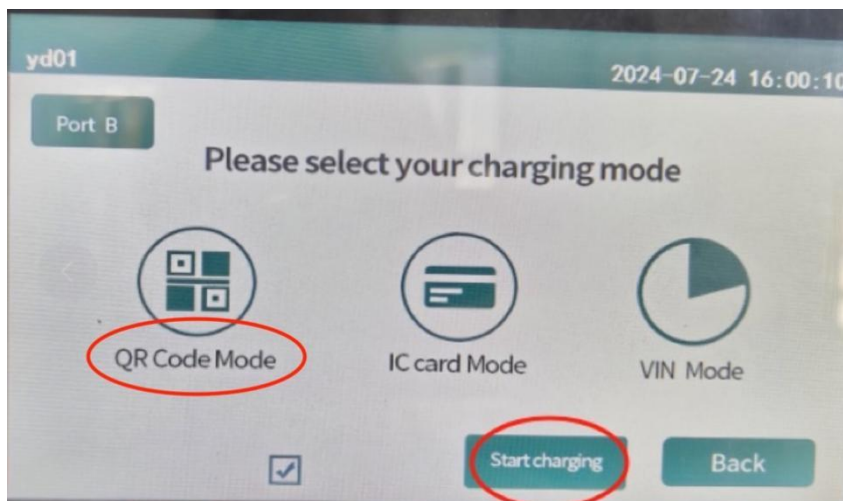

Charging Interface:

- Once charging starts, the interface will display relevant information about the connected port.
- Click “Fee Information” or “Battery Information” to view additional details.

As shown in the following figure:

Order Number:	
Charging Consumption:	
Card Number:	Amount:
Voltage:	Current:
Power:	Start Time:
Time Last:	Remaining time:

Charge Monitoring Charging Fee Info Battery Info Back

End of Charging

- To end charging, double-click the “End Charging” button on the charging interface.
- The interface will then display the settlement information for the connected port.

As shown in the following figure:

Settlement:	Amount:
Start SOC:	Charging Consumption:
End SOC:	Start Time:
Order Number:	End Time:
Reasons to End:	

Back

Attention



High Voltage:

Do not pull the connector directly when high voltage is present to avoid damage or serious injury.

Shutdown:

Operate shutdown via the screen or the APP.

Heat:

The EV charger surface may be hot during charging; do not cover vents.

Cleaning:

Do not clean the vehicle or the charger during charging.

Charging connector in place

- After charging is completed, return the charging connector and cable to the EV charger. Hang the charging cable on the hook and insert the connector head back into its seat.

- When the charging connector is connected to the vehicle, ensure the connector head is properly inserted into its seat to prevent dust or water ingress. To prevent the charging cable from causing accidents or tripping pedestrians, always hang the cable on the hook and insert the connector into its seat.

- After use, neatly wrap the cable to maintain its condition.

- To save energy, the EV charger screen will automatically turn off after about 18 seconds of inactivity. The charging connector is designed for 10,000 uses. After exceeding its service life or warranty period (whichever comes first), additional spare parts should be purchased.

- Damage to the charging connector caused by misuse, violence, or illegal operation is not covered under warranty.

- Any financial damages resulting from dangerous or violent operation shall be borne by the operator.

- The charging connector should not be subjected to violent impact, cable twisting, or illegal dragging.

- The operator is responsible for any failures caused by the charging connector being immersed in water without protection.

- Any failures or accidents resulting from exceeding the specified use conditions in this manual shall be borne by the user.

- Minors under the age of 16 are prohibited from operating the equipment. Any responsibility for incidents caused by minors shall be borne by the operator

Charging Abnormalities:

Charging abnormalities are not part of normal charging operations. Refer to this section only in case of abnormalities or misoperations.

- Emergency Stop: In case of an emergency, quickly remove the transparent protection cover and press the red "emergency stop" button. The system will cut off the power supply. Do not use the emergency stop button for normal shutdown.

- Undo the Emergency Stop: Rotate the emergency stop button clockwise to return to the charging state.

- Forced Connector Recovery:

-- Pulling out the charging connector during the charging process is very dangerous and strictly prohibited.

-- If the normal screen stop or swipe card stop operation cannot stop the charging process, press the emergency stop button.

-- Forcing the connector out may cause arc burns and the system will record the fault.

-- Click the confirm button to return to the charging shutdown state.

4.3 OCPP Network Settings

Example Set up access the wss: // dev.optima.az:8314/OCPP/intekdc22

SIM Card:

- ① Insert the SIM card into the OCPP control board;

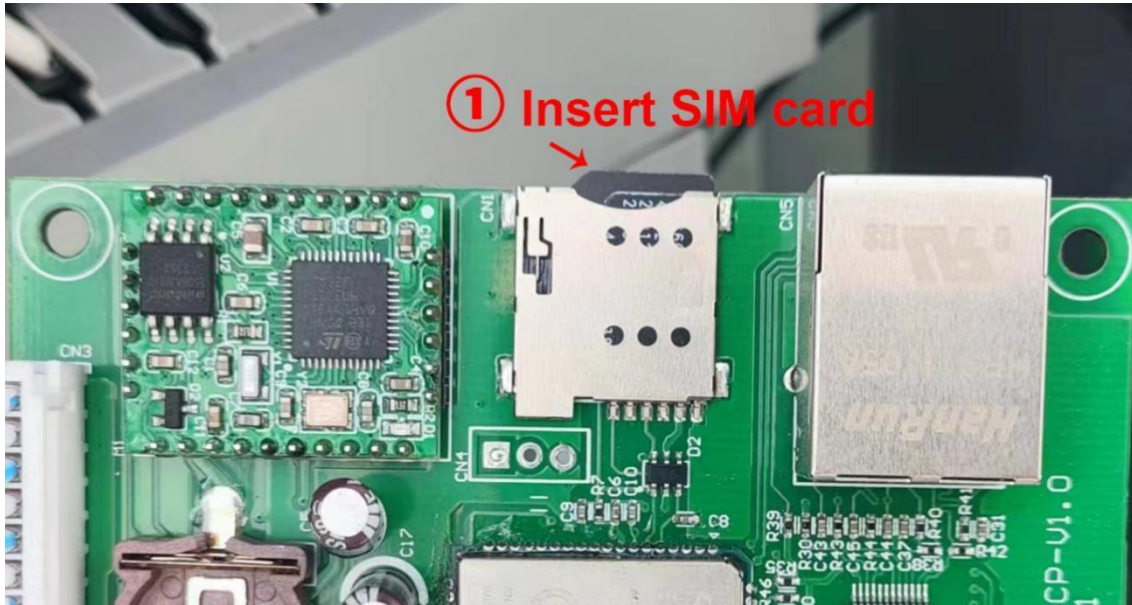

- ② Turn on the single-phase air switch, proceed after the screen is on.

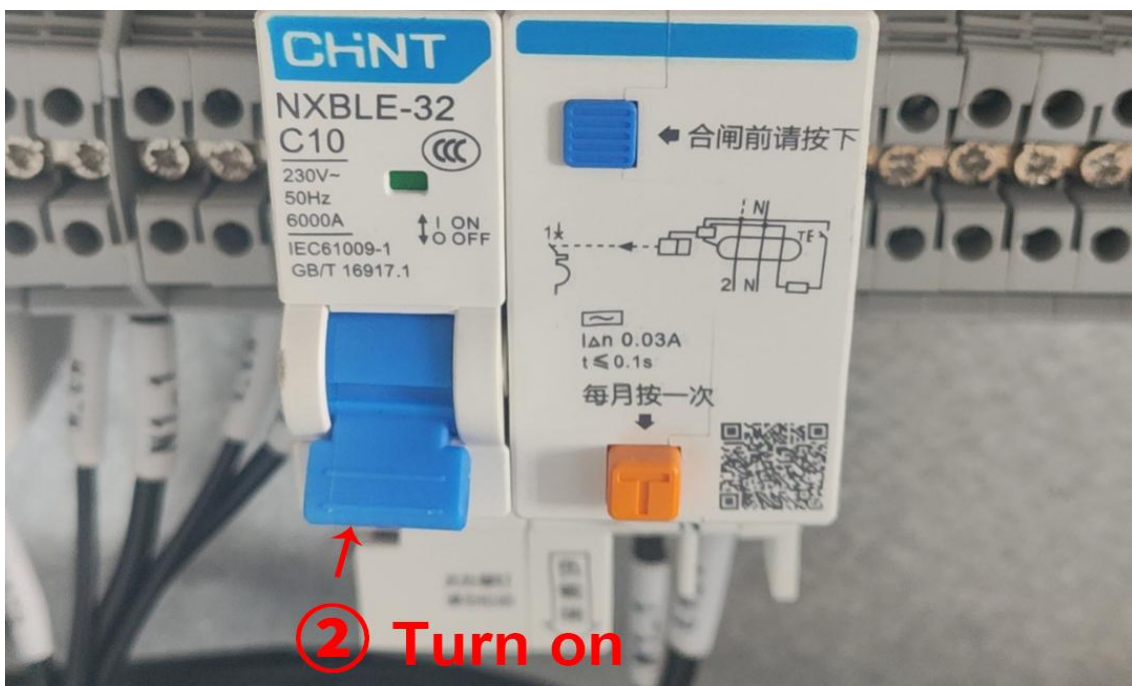

- ③ Double-click the green space above the screen center (as shown below)

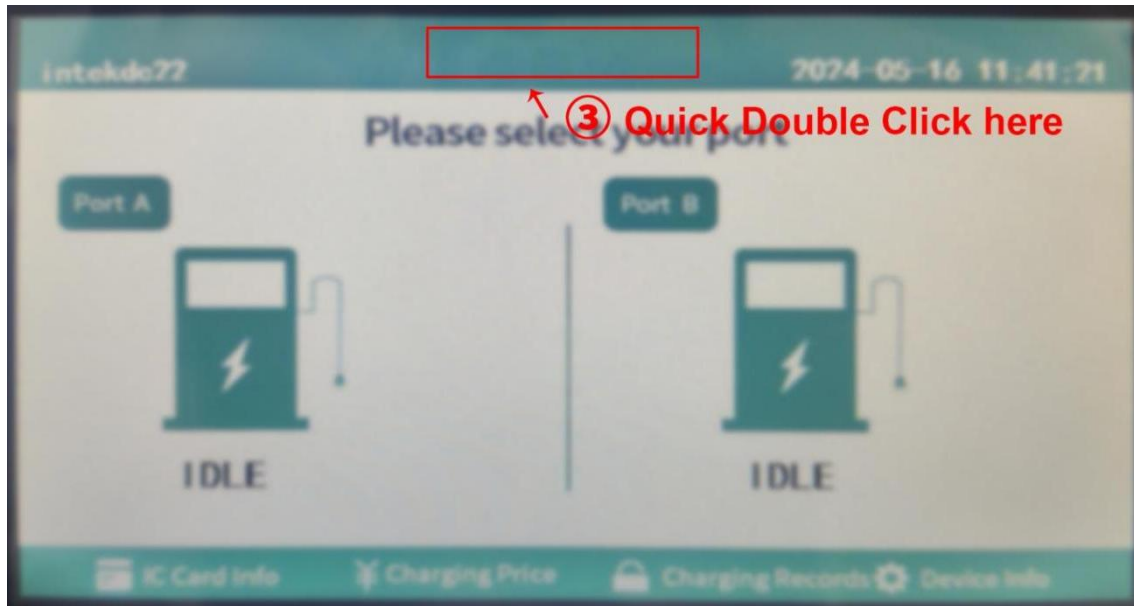

- ④ Click the blank of the input display box and enter 159357

- ⑤ Click "confirm" to enter the Settings interface;

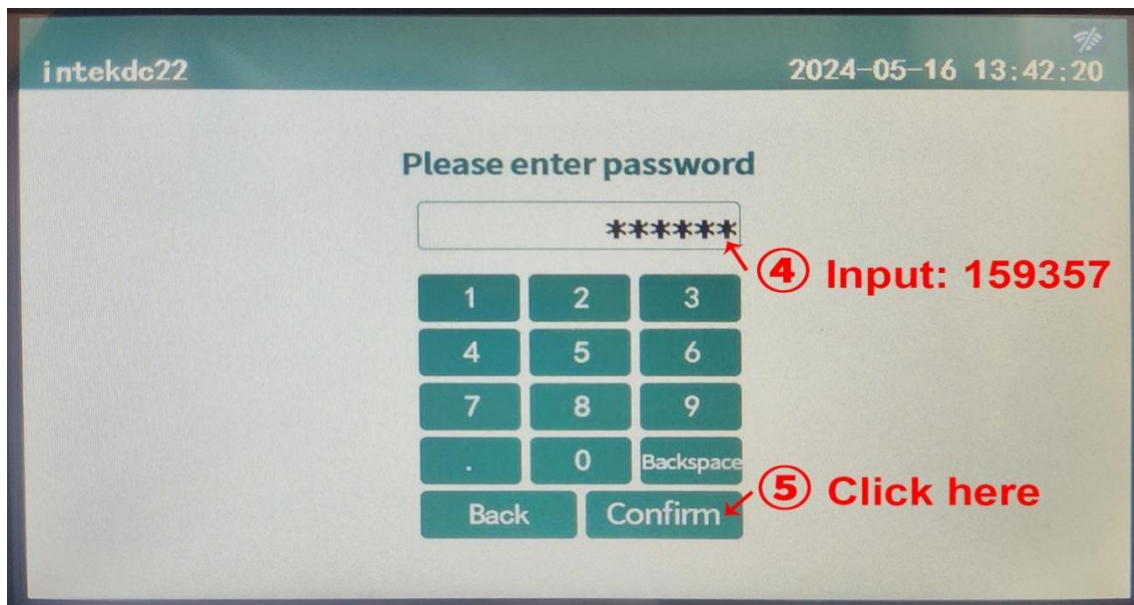

⑥ Set the Charger ID of OCPP (pile given by OCPP provider), and the url of Charger is wss: // dev.optima.

A z: 8314 / OCPP / intekdc22, then enter intekdc22;

⑦ Set the platform to OCPP , if not already set;

⑧ Click "Network Settings", after setting the charger number and charging platform,

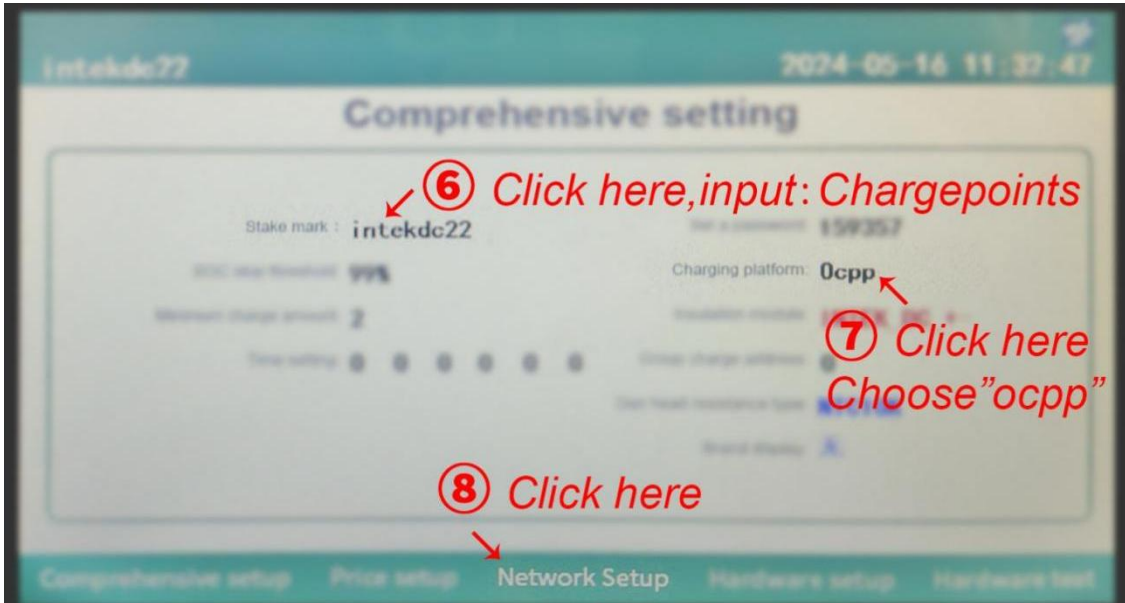

⑨ Click GPRS4G or ETH on the right of the screen, if it is already GPRS4G, no click;

⑩ Adjust OCPP Path: Chargepoints url to wss: // dev.optima.az: 8314 / OCPP / intekdc22, enter wss: // dev.optima. Az: 8314 / OCPP /, then confirm;

*** Note: Note the double character keys on the keyboard (upper and lower characters), need to use Caps Lock to switch; for example: ':' needs to use Caps lock to input, do not enter ','; click Caps Lock again to switch to normal state before entering letters and numbers.**

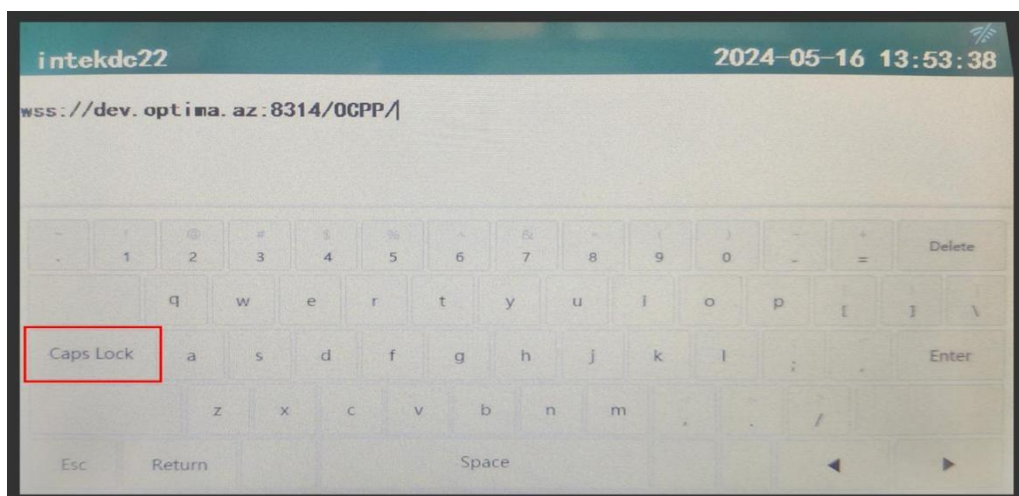

⑪ After returning to the interface, click the bottom left button of the screen to go back to the comprehensive Settings interface. Then, click the bottom left button again to return to the initial interface;

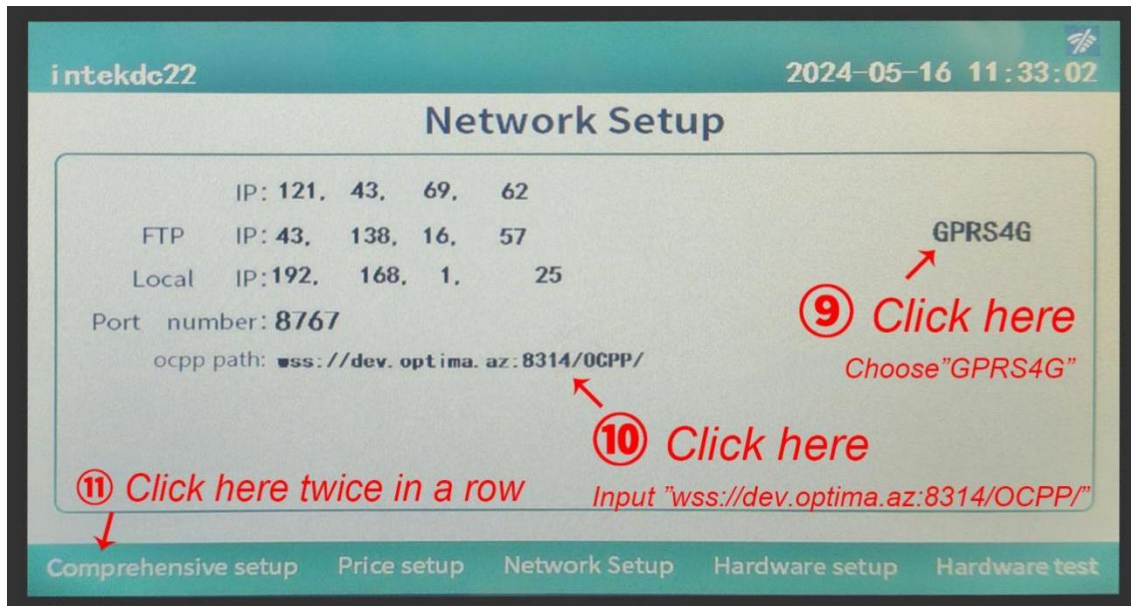

⑫ After returning to the initial interface, restart the charging pile and wait for 1~5 minutes, when the signal mark is displayed in the upper right corner of the screen, the communication is successful;

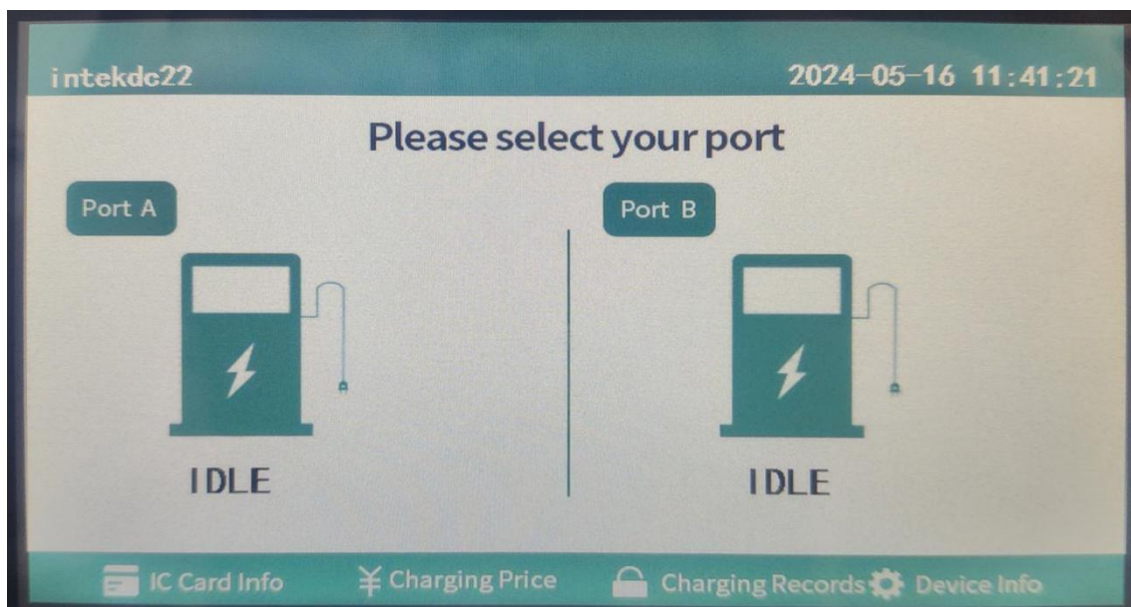

Ethernet cable setup:

- Insert the Ethernet network cable into the subnet cable slot on the OCPP control board (as shown below);
- Follow the same step as described for the SIM card mode;
- Change the Network Setup interface on the right side to ETH.

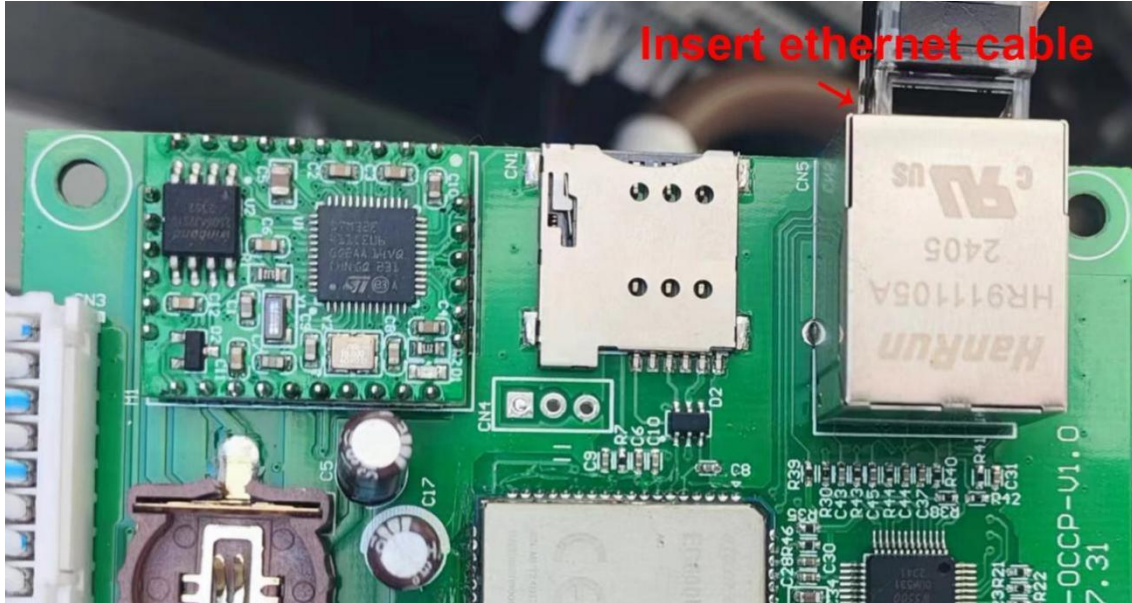

Click ETH on the right of the screen, if it is already ETH.

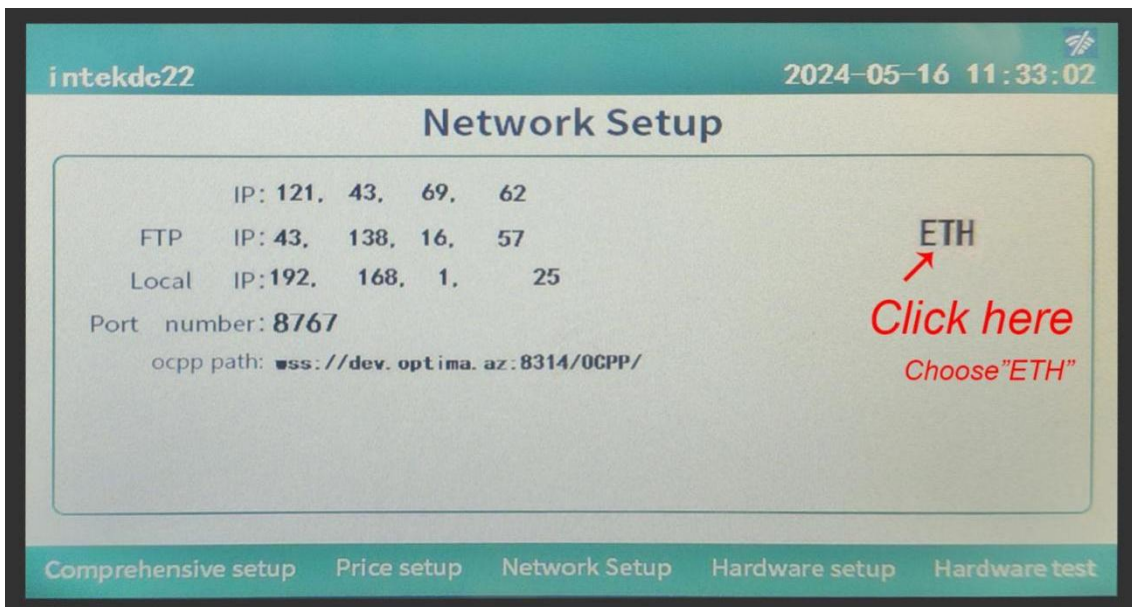

Then return to the original interface, restart and wait for its communication.

4.4 Operational Integration

- After startup, the charger connects with the cloud platform for remote management, diagnostics, and updates.

Integration with Existing Customer Operation Platforms:

- Our company supports integration with existing customer operation platforms through the OCPP protocol.

Please contact our sales or service engineer for assistance.

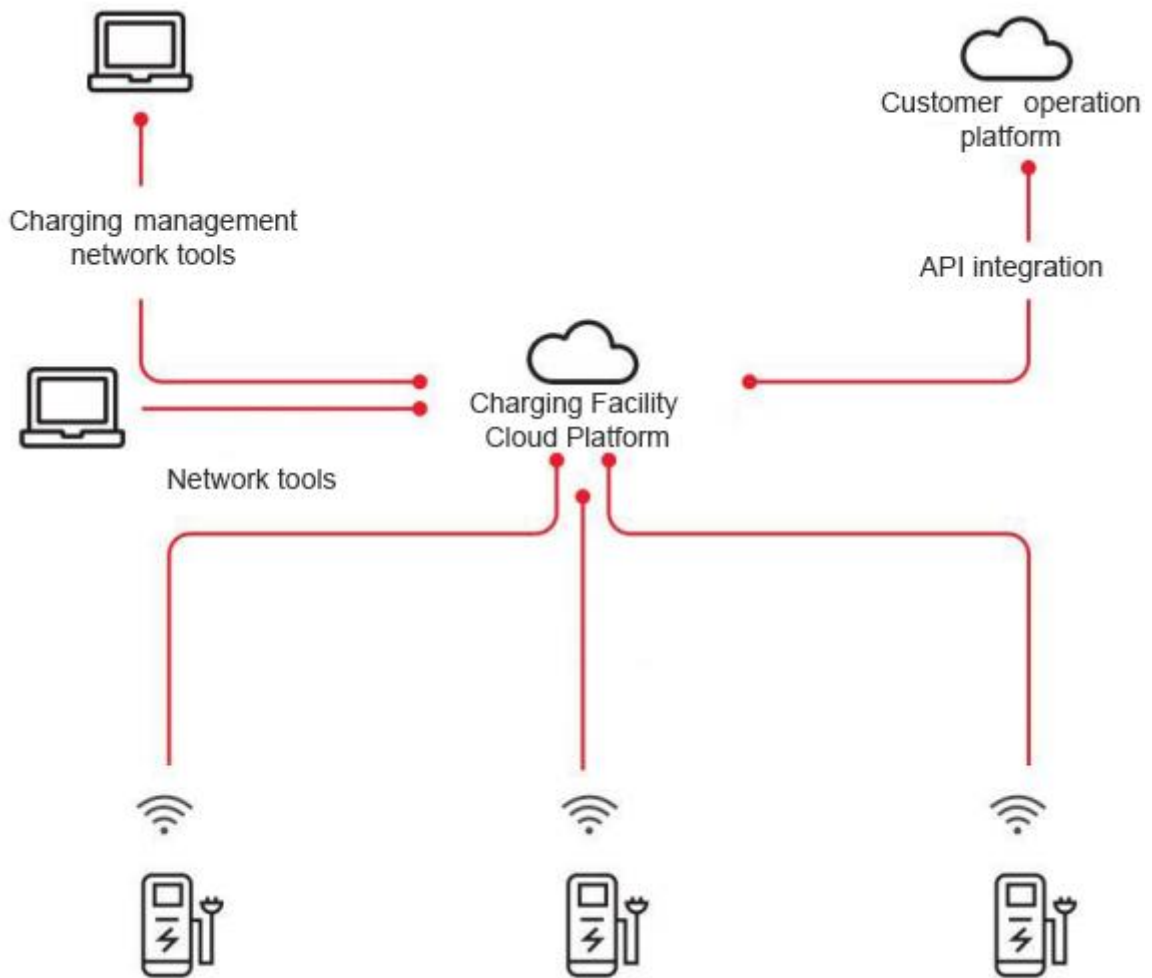

V.Maintenance Instruction

5.1 Daily Maintenance

Daily maintenance can keep the EV charger in a safe and stable and good state.

- Clean up the outer surface of the EV charger every two months
- Tighten the screw bolts at key parts every quarter
- Clean the air filter cotton and dust filter at least once every six months
- Test the leakage protection device once a year

Clean the Appearance

The outer surface of the EV charger is sprayed with powder, which needs to be kept in good state and maintain a beautiful image.

- Stop all the charging process, cut off the power supply, and plug in the charging connector
- Use wet, dust-free cloth to remove foreign matter and dust from the surface of the cabinet
- Only use strong stains with pH between 6 and 8, and then wash with clean water

Test the Electric Leakage Protection Device

Leakage protection is a crucial safety system that must be tested annually. Do not test the device during charging. Ensure all charging processes are stopped and the EV charger is disconnected from the vehicle.

- Open the front and side doors of the EV charger, avoid exposing the open cabinet to stormy weather.
- The EV charger must be in standby mode, which can be activated by touching the screen.
- Press the "Test" button for the leakage protection device:

- OK : The leakage protection device switches to the "off" position, stopping the EV charger. Reset the device by switching to the "on" position.

- Bad: If there is no reaction, disconnect the AC power supply, close the cabinet door, and do not use the charger until the leakage protection device is repaired. Contact our company or local supplier.

- Close the side and front doors of the EV charger.
- Record the time required for testing the leakage protection device annually.

Clean and Replace The Air Filter Cotton and Dust Filter

The EV charger is equipped with air filters to protect electronic components from dust. Clean the air filter and dust gauze at least once every six months.

- Always stop all charging processes before cleaning or replacement.
- Open the side door of the EV charger; avoid exposing the open cabinet to stormy weather.
- Unscrew the hand screws, remove the baffle, and the original air filter.
- Clean debris or dust from the filter and dust gauze.
- Install the cleaned filter, then replace the baffle and screws.
- - Close the side door.



Attention

Operating the EV charger without the air dust filter, or failing to replace it on time, will damage the device. Resulting faults are not covered under the warranty.

5.2 Advanced Maintenance

This EV charger is an Internet of Things (IoT) device with intelligent functions such as pre-charging self-inspection, daily regular self-inspection, and online monitoring of electrical parts and operating parameters.

- Under normal operation, only daily maintenance is required.
- In case of abnormal operation, please refer to the fault handling guidelines.

VI. Fault Treatment

6.1 Fault Identification

The EV charger installed in open places may fail due to various reasons, which should be roughly identified:

Improper Use of Fault

- Emergency stop button pressed
- Forced connector pulled

Charging System Failure

- See the list in the "Processing Methods" later

Electric Vehicle System Failure

- Abnormal system faults, abnormal voltage, abnormal insulation and other faults of electric vehicles will

lead to charging failures.

Man-made Fault Destruction

- the charging connector to crack, press, soak water
- The charging cable is rolled over and pulled by the wheel
- The charging cable is pulled and broken by the external force
- the EV charger is hit by a driving vehicle or a heavy object
- The door of the EV charger cabinet is opened abnormally
- Air duct blockage, etc

Note, human damage failure is not within the scope of warranty service

Natural Disaster Failure

- Earthquake damage
- Heavy rain flooding
- Lightning disaster
- An external fire

Note, the natural disaster failure is not within the scope of the warranty service

6.2 Treatment Method

No.	Display Status	Possible Cause	Suggest How to Deal With	Preliminary Treatment Party
1	Black screen, no touch response	AC input to the charging station is off	Check if the charger's input power supply is normal:ensure each phase of the two-phase input voltage is ~220V, with a line voltage of ~380V. Inspect for any leakage or short circuits in the input cable. If input is normal, try restarting. If the issue persists, contact our service personnel.	Customer operation and maintenance / Company service
2	Screen Flickering, white screen, incorrect display	Continuous 24-hour operation causing display freeze	Try restarting the power. If the issue persists, contact our service personnel for assistance.	Customer operation and maintenance/ Company service
3	Display: insulation detection fault	Insulation fault in the vehicle or EV charger	Replace the EV charger and attempt charging again. If the problem persists, it is likely an issue with the vehicle. If the fault does not recur, it indicates a problem with the EV Charger. Contact our service personnel for further assistance.	User/ Company service
4	Other issues not listed above	Various potential causes	Contact our service personnel for further assistance.	Company service

6.3 Maintenance Records

No.	Fault Description	Maintenance Method	Result	Attendant	Date	User
1						
2						
3						
4						
5						
6						
7						
8						

The above forms are used for maintenance records.

User Name (Company / Mr. / Ms.):

contact number:

installation time:

VII.After-sale Service

When the product becomes unusable, please contact us through your local operator. We will arrange for professional engineers to provide remote guidance until the issue is resolved.

Alternatively, you may email us with your requirements, and we will promptly provide the necessary assistance.



Email address: heshiyu.1988@163.com



180kW DC CHARGING

Installation and User Manual

Thank you for choosing our DC charging station product. To help you install and use the charging station correctly, please read this manual carefully and keep it safe. If you still have any questions about any of the contents, please contact our company in a timely manner and seek help. Our company reserves the right to modify the technical features and content in this manual.



















CATALOGUE

I. Security Statement	- 1 -
1.1 Safety Identification	- 1 -
1.2 Safety Warning	- 2 -
1.3 Liability Statement	- 2 -
II. Product Overview	- 4 -
2.1 Product Parameters	- 4 -
2.2 Functional Features	- 5 -
2.3 Product Description	- 7 -
III. Installation Instructions	- 11 -
3.1 Construction Preparation	- 11 -
3.2 Installation and Preparation	- 13 -
3.3 Installation Steps	- 16 -
3.4 Installation and Adjustment	- 21 -
IV. Direction for Use	- 22 -
4.1 System Startup	- 22 -
4.2 Charging Operation	- 23 -
4.3 OCPP Network Settings	- 28 -
4.4 Operational Integration	- 33 -
V. Maintenance Instruction	- 34 -
5.1 Daily Maintenance	- 34 -
5.2 Maintenance and Maintenance	- 35 -
VI. Fault Treatment	- 36 -
6.1 Fault Identification	- 36 -
6.2 Treatment Method	- 37 -
6.3 Maintenance Records	- 38 -
VII. After-sale Service	- 39 -

I.Security Statement

1.1 Safety Identification

	<p>Refer to Instruction Manual</p> <p>It typically signifies that user guide manuals or original documents must be kept properly for future use, and must not be damaged in any way</p>
	<p>General Warning</p> <p>Important security information that must be very carefully observed</p>
	<p>Dangerous Voltage</p> <p>Indicates situations where dangerous voltage must be handled with extreme caution</p>
	<p>High Temperature Warning</p> <p>Represents the burn hazard in high temperature areas or areas with high component temperatures</p>
	<p>Hazard of Injury Due to Equipment Weight.</p> <p>Indicates careful lifting and transport are required to avoid injury</p>
	<p>Prohibition Notice</p> <p>It means that entering the relevant area or performing the operations is prohibited</p>
	<p>Avoid Child Contact</p> <p>Indicates that the equipment should be kept out of reach of children</p>
	<p>No Smoking and Using Open Fires are Allowed</p> <p>Indicates prohibition of smoking and use of open flames near the equipment</p>
	<p>Personal Protective Equipment</p> <p>Indicates that the operations must be performed using clothing and / or personal protective equipment provided by the employer</p>
	<p>Ground Protection Connection Point</p> <p>Indicates the designated connection point for ground protection</p>
	<p>Allowable Temperature Range</p> <p>Indicates the range of temperatures within which the equipment can operate safely</p>
	<p>Direct Current</p> <p>Indicates the use of direct current(DC)</p>
	<p>Alternating Current</p> <p>Indicates the use of alternating current(AC)</p>
	<p>Positive Electrode of the Input Voltage</p> <p>Indicates the positive electrode for input voltage/current</p>
	<p>Negative Electrode of the Input Voltage</p> <p>Indicates the negative electrode for input voltage/current</p>
	<p>Note Content Identification Suggestions or Comments</p> <p>Indicates notes or suggestions for the content</p>

1.2 Safety Warning

The company's EV Chargers are designed and tested in strict accordance with the relevant national and international safety standards. However, the safety of power electronic equipment is not only affected by the quality of the equipment itself, but also highly related to handling, installation, trial operation, operation, maintenance, demolition and other operations. Incorrect use or misoperation will lead to the following risks:

- Risks of electric shock, short circuit, fire, explosion, and severe burns;
- Harm to the life and personal safety of the operator or a third party;
- Damage to the EV Charger or other property.

To avoid safety accidents, the following safety precautions should be strictly observed during installation and maintenance.

- All preparation, installation, movement, maintenance and disassembly, must be completed by professional and technical personnel. Unauthorized loading and unloading are prohibited.
- Professional and technical personnel must be qualified and trained or proven to have skills and knowledge in the structure and operation of EV Chargers;
- Read this manual completely and understand the relevant safety matters.

1.3 Liability Statement

Owner Responsibility

Requirements for Charging station owners and field operators:

- Run the charging station with full implementation of protective measures ensuring the correct installation and regular maintenance of protective facilities;
- Prepare an emergency plan to handle emergencies effectively;
- Prepare the installation site according to the requirements described in this manual;
- Ensure sufficient space for passage and maintenance of the EV Chargers;
- Assign a person responsible for safe operation and overall coordination;
- Understanding that unauthorized changes can affect the operation authorization or warranty.

Disclaimer

The Company shall not be liable for accidents or damage caused by:

- Human factors or abnormal working environments;
- Faults and damage caused by not following the instructions;
- Damage due to poor transport after delivery;
- Normal wear and tear, rupture and immersion dyeing;

- Products not belonging to the company (eg: counterfeit goods);
- Unauthorized disassembly, repair, or modification
- Damage due to other non-resistance (such as flood, fire, lightning strike, typhoon, earthquake, abnormal voltage);
- Use beyond the service life not covered by warranty;

II.Product Overview

2.1 Product Parameters

No.	Product	Dc Charger For Electric Vehicles
1	Input Line System	Three-phase five-wire 3P + N + PE
2	Input Voltage	380V/400V AC \pm 15%, 50Hz/60Hz
3	Rated Power	180kW DC
4	Power Factor	\sim 0.99 (Full load)
5	Output Voltage	200—1000VDC
6	Constant Power Area	300—1000VDC
7	Maximum Current of Single Connector	250A DC
8	Cabinet Dimensions	800mm*630mm*1830mm (excluding Connector holder)
9	Levels of Protection	IP54
10	The charging Cable Length	5m
11	Noise	\leq 75dB
12	Working Temperature	-20 $^{\circ}$ C \sim +50 $^{\circ}$ C
13	Storage Temperature	-20 $^{\circ}$ C \sim +70 $^{\circ}$ C
14	Working Humidity	Relative humidity 5% to 95%
15	Working Altitude	Up to 2000m (above 2000m needs special consideration)
16	Gas Medium	Should avoid explosive, corrosive and harmful gases and conductive media
17	Open Installation	Suitable for all-weather open-air installation
18	Verticality	Mounting vertical inclination should not exceed 5 $^{\circ}$
19	Cable Entry	Bottom entry for cables
20	Cable Outlet	The upper cable outlet of the cabinet is designed to be waterproof and resistant to immersion, rain, and snow. It also prevents tripping hazards for pedestrians and vehicles.

2.2 Functional Features

Safety

- Unique safety mechanisms including pre-charging protection, main circuit safety detection and remote diagnosis management
- Basic protection measures such as lightning protection, overvoltage, overcurrent, short circuit, connection fault, and emergency stop
- Comprehensive charging protection functions and mechanisms that effectively guarantee the safety of personnel, prevent overcharging, and ensure operational safety

Intelligence

- The terminal EV Chargers and the cloud platform intelligent Internet of Things can perceive more than 100 underlying operating parameters in real time
- Features remote diagnosis, remote reset, and remote upgrade capabilities.

Reliability

- Independently designed hardware and software, from circuit boards to system architecture, and from embedded software to cloud platform, ensuring high consistency, compatibility and stability
- Performance Metrics such as current accuracy, voltage accuracy, leakage protection accuracy, ripple harmonic, and standby power consumption exceed industry averages.
- Utilizes international first -line brand components for high system reliability. The wind duct maze design effectively prevents issues such as splashes and accidental collisions, making it suitable for installation in urban public parking lots and roadside parking spaces.

Convenience

- Flexible networking options with both wireless and wired communication modes.
- Anti-sunlight liquid crystal display with a user-friendly interactive interface
- Open communication protocol supporting code scanning charging, API services, and energy demand response

Interactive Function

- All charging stages include intuitive and friendly illustrations and text prompts on the screen.
- The screen features an anti-sunlight display and is ergonomically arranged for ease of use.

Measurement function

- DC metering function with an accuracy level of 1.0.

Communication Function

- Supports Ethernet access and 4G wireless communication networking.

Payment Function

➤ The EV Charger provides charging consumption time and quantity information to the operation background which centrally controls the charging strategy. The integrated system supports various payment methods such as card swiping, code scanning, and mobile app payments.

- Customizable optional POS machine supporting VISA and international credit card payments.

Self-Test and Self-Repair Function

➤ During power operation, the EV Chargers conducts a self-check of the equipment's working environment, power supply, data storage space.

➤ Fault information is displayed on the screen, recorded, and stored in the superior monitoring and management system.

➤ Automatically monitors the operation of key components, including but not limited to charging connectors connection self-test, contactor adhesion self-test, and power unit state self-test.

Remote Internet of Things Function

➤ The EV Chargers connects with the device cloud platform to monitor numerous parameters in real time providing comprehensive remote diagnosis, remote service, and remote upgrade service

Diagnostics include checks for whether the charger cabinet door is opened, whether the emergency stop button is pressed, whether the AC contactor is disconnected, whether the vehicle is connected, whether the connector head temperature is too high, and whether the insulation test is normal.

2.3 Product Description

Product Appearance

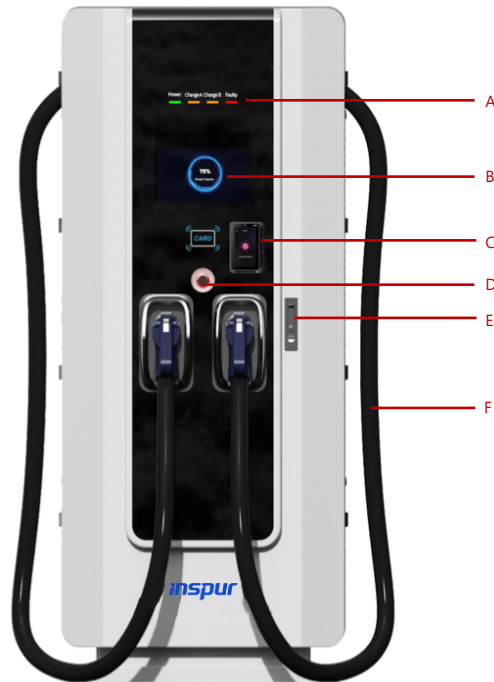

A.LED Indicator Light

B.User Interface Display Screen

C.POS Machine (Configuration Options)

D.Emergency Stop Button

E.Cabinet Lock

F.Charging Cable

Note: Due to the version iteration, there may be some differences between photos and physical objects.

Inner Structure

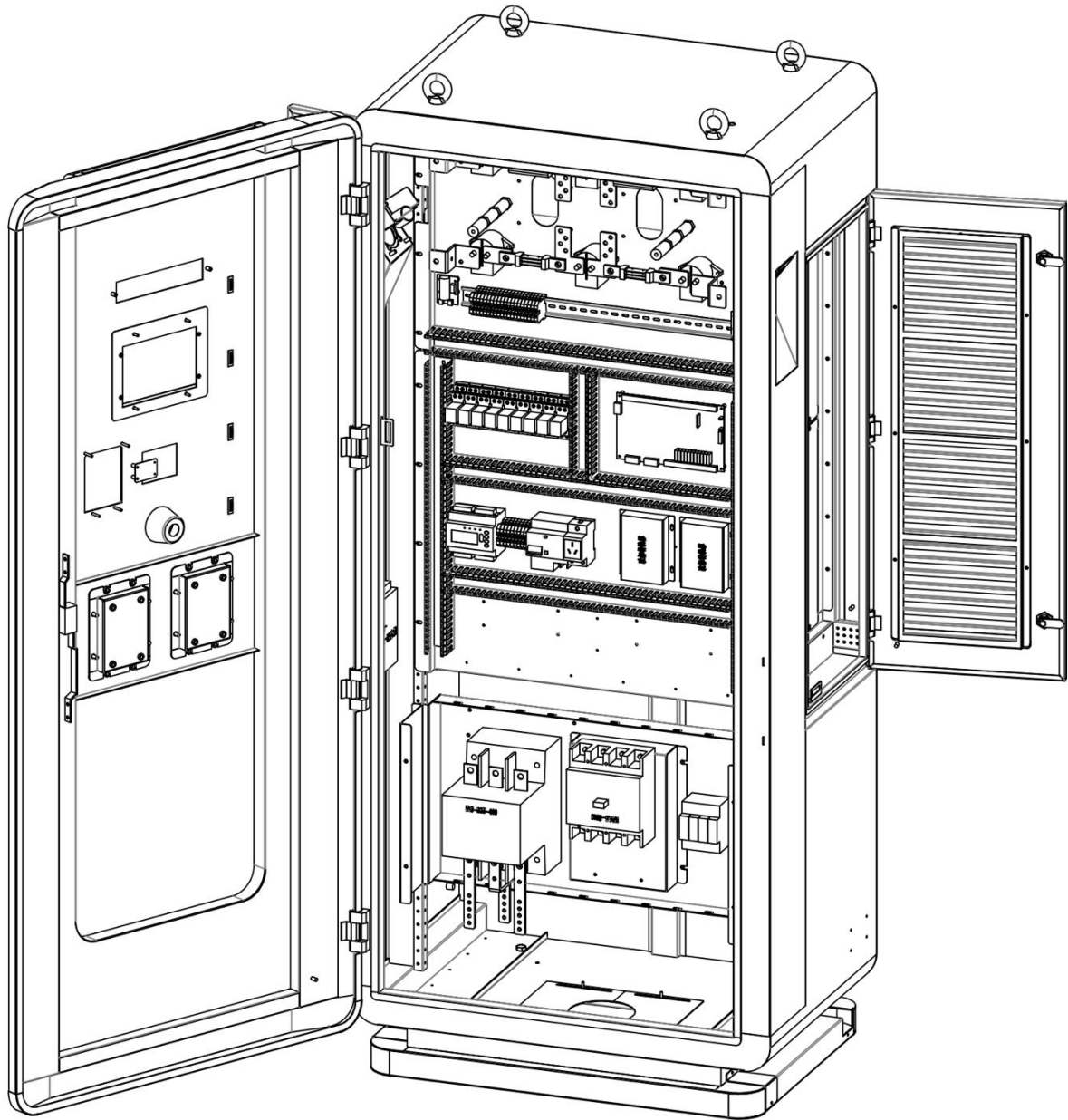

Note: Due to the version iteration, there may be some differences between photos and physical objects.

Space Requirement

To ensure the safe and reliable operation and convenient maintenance of the equipment, sufficient space for installation must be reserved.

The space requirement during installation is 1800mm * 1680mm, calculated as follows:

- **Dimensions(W * D * H):** 800mm * 630mm * 1830mm (excluding connector holder)
- **Front Side Clearance:** Reserve 1000mm to ensure the normal operation of the front door switch and smooth functioning.
- **Left Side Clearance:** Reserve 500mm to allow for normal operation of the front door and smooth functioning.
- **Right Side Clearance:** Reserve 500mm to enable normal operation of the side door , maintenance space for the charging module, and smooth airflow into the air inlet.
- **Rear Clearance:** Reserve 50mm to ensure that the side doors on both the left and right are not obstructed.

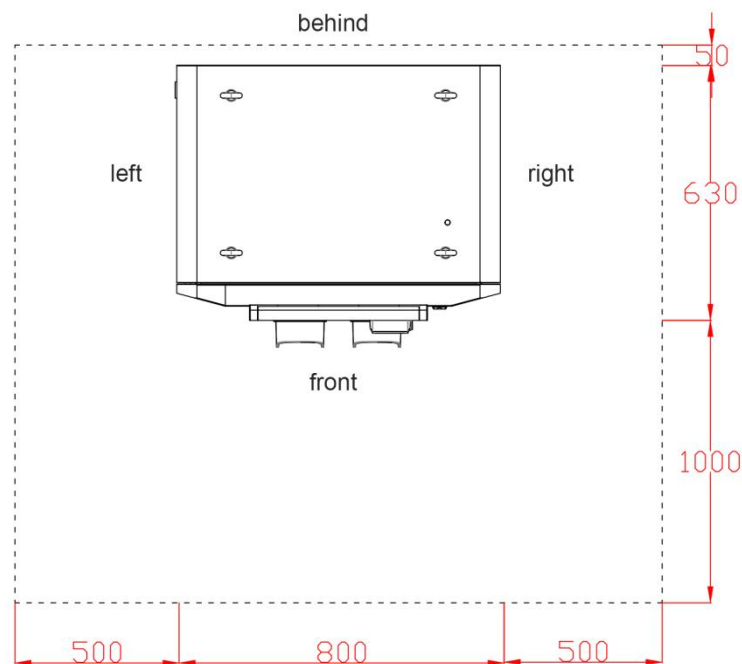

Ventilation Requirements

The EV Chargers converts AC to DC to charge electric vehicles. During this conversion process, some energy is lost as heat, necessitating efficient heat dissipation. Therefore, it is essential to ensure that the installation space has open and continuous airflow, and that the main air inlet and outlet paths are not blocked. It is not recommended to install the charger in a confined space without ventilation. The product's air inlet is located on the right side of the screen, and the air outlet is on the left side.



Attention

Ensure Unobstructed Airflow:

Preventative measures should be taken to keep the air ducts clear.

Avoid any obstructions, such as snow or foreign objects, from blocking the air inlet and outlet.

III. Installation Instructions

3.1 Construction Preparation

About the Construction

The construction phase includes all tasks necessary to prepare the installation site for placing and connecting the EV charger. The following conditions must be met to begin the construction phase:

- All engineering preparations are complete
- All necessary permits have been obtained
- The grid can be connected

Cable Entry

The cable should enter through the bottom of the EV charger.

Infrastructure Projects

The suitability of the installation site is related to the surface type of the infrastructure construction.

Foundation Requirements

-Indoor Installation: A foundation is not required if the equipment is installed indoors or in other high and dry places. The ground smoothness error must not exceed $\pm 1.5\text{mm}$ per square meter, and the ground strength at the installation position should be at least C30.

-Outdoor Installation: When installed outdoors or in areas prone to water accumulation, a cement or tank steel base must be used. The cement base should be 200mm high, with a recommended depth below ground of at least 500mm. Four M12 stainless steel bolts should be embedded in the installation surface, extending $40 \pm 3\text{mm}$ above the ground. The foundation design should be tailored to the actual site conditions.

-Instructions:

- Excavate a pit at the installation site as specified.
- Ensure the cable can enter through the embedded pipe, with an aperture of at least 100mm.
- Pour the concrete foundation as illustrated.
- Ensure the EV charger's base height is at least 200mm to reduce flooding risk.
- Expose 0.7m of cable length above the foundation for internal wiring.

Fill the foundation's inner and outer holes with sand and stone, and seal the inlet holes with fireproof mud to prevent small animals from entering the equipment.

Base Hole Position and Installation Method

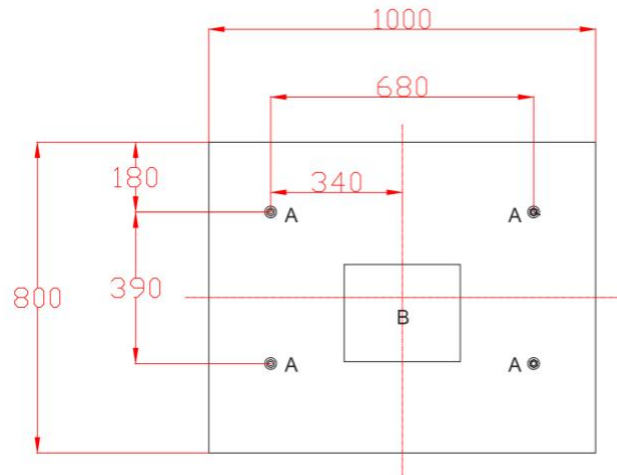

- Figure A: Embed four M12 stainless steel bolts.(screw anchor)
- Figure B: Identify the power cable entrance location.
- Exposed cable length for internal wiring is 0.7M

Cable Protection Requirements

- **Cable Type:** three-phase and five-wire system (3P + N + PE),
Verify if shielding is required based on local laws.
- **Shielding Layer:** Connect both ends of the shielding network with the PE safety ground wire if present.
- **Cable Diameter:** Determined by the contractor or electrical engineer based on power, distance, and industry standards.

- **PE Safety Ground Wire:** Should match the N wire model size.

- **Recommended Cable Cross-sectional Area:**

-For 180kW: YJV 4 * 150 + 1 * 70

- The cable must comply with national and local standards.

- Each EV charger must have independent open and leakage protection.

Network Connection Requirements

-**Standard:** 4G wireless communication module integrated with the EV charger. Users should prepare a SIM card. If no 4G signal is available, use a standard wired Internet connection.

-Wired Connection Requirements:

--**The RJ 45 Ethernet:** 8P + PE, shielding wire.

-- **Recommended Length:**

Up to 75m, refer to HELUKAT 600E.

For lengths over 75m, an engineering scheme is required.

--The Minimum Bandwidth:

Uplink: 128 kbps

Downlink: 4 Mbps

--Connection Dependability: 99.9%

3.2 Installation and Preparation

Transport Loading and Unloading

- Handle heavy equipment with care.
- Use appropriate load-bearing equipment such as forklifts, cranes, or towing trucks, operated by professionals.
- Avoid dumping or crashing the equipment.

Keep the device upright, with a tilt angle not exceeding 30 degrees.

Arrival Inspection:

- Check for package damage and label correctness upon arrival. If any abnormality is found, inform the carrier, take photos, and collect evidence. Sign the documents and contact the manufacturer for further action.
- Verify that product accessories and accompanying documents are complete according to the packing list.
- Inspect the product visually for any signs of collision, scratches, cracks, corrosion, damage, or paint peeling.
- Check the charging connector for any abnormalities such as crushing, rust, damage, or loose connections.
- Sign documents, save records, and distribute or transfer them to related parties.

On-site Confirmation

- Ensure that the site's altitude, coordinates, temperature, humidity, ventilation, load-bearing capacity, installation position, maintenance space, and power supply meet the equipment's requirements.
- Confirm that the on-site 4G signal strength is good (signal strength greater than -85 dBm, or above 50% full grid strength as observed on a mobile phone).
- Verify that all necessary licenses are in place.
- Confirm that the project preparation work is complete and the power grid connection is available.
- Avoid starting installation if construction is ongoing at the site to prevent damage from building materials, dust, paint, muck, or litter. It is recommended to install the EVcharger after construction is completed.

For short-term or long-term storage, store the equipment in a dry, well-ventilated indoor place, away from high temperatures, humidity, dust, metal powder, and corrosive gases.

Important Notes:

- Due to the complexity and danger of EV charger installation, only qualified professional and technical personnel should perform the installation according to this manual.
- Prepare and check relevant tools and devices, ensure personal protection, and wear protective gloves during installation to prevent injuries from metal parts. Use appropriate lighting devices if needed.
- Ensure all switches associated with the equipment are in the off state (when repairing or replacing spare parts, ensure the equipment is well grounded).

Use professional tools to confirm the power supply is disconnected, with no power input and output to the equipment. Ensure each charger has independent protection and disconnection conditions, and use a special power interface with proper grounding. Fire and neutral wires must not meet. Turn off the power and take reasonable measures to prevent the power switch from closing automatically.

Installation Tools

Name	Main Role	Quantity
Multimeter	Check Electrical Connections and Parameters	1 pc
Electric Impact Drill	Drill Holes	1 pc
Impact Bit (Φ 16mm)	Drill Bit	2 pcs
Band Tape	Measure	1 pc
Leveling Instrument	Measure	1 pc
Slotted Screwdriver	Open	1 pc
Plier	Open	1 pc
Wire Stripper	Remove Insulation Sheath	1 pc
Terminal Crimping Pliers	Crimp Terminals	1 pc
Diagonal Pliers	Cut Cables	1 pc
Adz-eye Hammer	Unpack, Tap and Adjust	1 pc
Transport Equipment	Move and Hoist EV Chargers	1 set
PVC Insulation Tape	Insulate Connections	1 roll
Personal Protection Tools	Ensure Operator Safety and Health	1 set/ personnel
Multi-Function Crowbar	Remove Wooden Box	1 pc

Basic Tools

Order Number	Nut /Bolt	Tool	Installation Site
1	M12 Hexagon Nut	19 # Tools Included With The Charger	Base Installation (fixed to cement base)
2	M8 Inner Hexagon Bolt	6mm Inner Hexagon Spanner	Input Ground Wire, ABC Phase Power Input, N Wire Installation
3	M10 Inner Hexagon Bolt	8mm Inner Hexagon Spanner	180kW Cable, ABC Phase Power Input, N Wire Installation

Installation, Repair, and Replacement of Spare Parts

Safety Precautions:

- Live work is strictly prohibited
- Unauthorized disassembly is strictly prohibited.
- Ensure equipment operation safety.
- Follow the sequence PE ground wire > zero wire > phase wire for power supply line access.
- All operations must comply with the relevant safety standards

Post-installation, Repair, and Replacement

- Perform acceptance and testing according to installation and maintenance requirements.
- Organize and collect tools, restore the internal switch to the working state.
- Lock the safety door to maintain equipment safety.

3.3 Installation Steps

Receiving the Goods

EV charger products can be delivered by the transportation company to the destination warehouse or the agreed location. For standard orders, the factory is not responsible for delivering the equipment to the final installation point. Prepare personnel and equipment for unloading and transfer at the receiving site.

Removing the Packaging

Use a multi-functional crowbar to remove the outer packaging, and use scissors or an art knife to remove the inner packaging.

Installation Preparation

- Open the side cover plate of the base, release the clamp cylinder, open the stack plate screw, etc.
- Unscrew and keep the screws on the base side cover plate.
- Remove and safely store the side cover plates and the front door of the EV charger.
- Open the front door of the EV charger
- Check for any abnormalities such as loose threads or parts.
- Reattach the side door and front door in sequence.
- Unclip the bolts securing the cabinet to the stack plate.

Placing the Equipment in Position

Move the equipment to the pre-made concrete base using one of two methods:

- 1: Lift the EV charger into position using optional lifting rings.
- 2: Use a lifting forklift to carry the EV charger into place.



High Voltage Safety

Ensure that the main and auxiliary circuit switches of the EV charger are disconnected. Perform voltage detection to confirm no current is present in the wires and system.



Warning

Handling the EV charger after delivery is not covered under warranty. Handle with care during transportation and installation.

Handling EV Charger

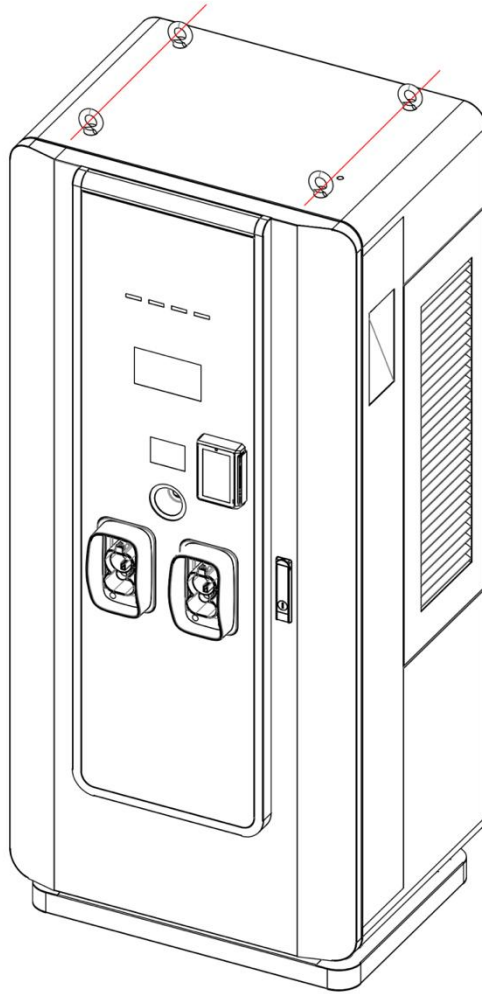

- Open the base-side cover plate
- Use the forklift truck to pass through the designated red line position as shown
- Carefully move the EV charger to the installation position

Locking the equipment

Preparation

- Tool: 19# wrench (for fixing M12 hexagon nuts).
- Raise the EV charger by about 0.5m and place it above the installation position.
- Pass the traction power cord through the cable envelope.

Placing the Cabinet to the Base

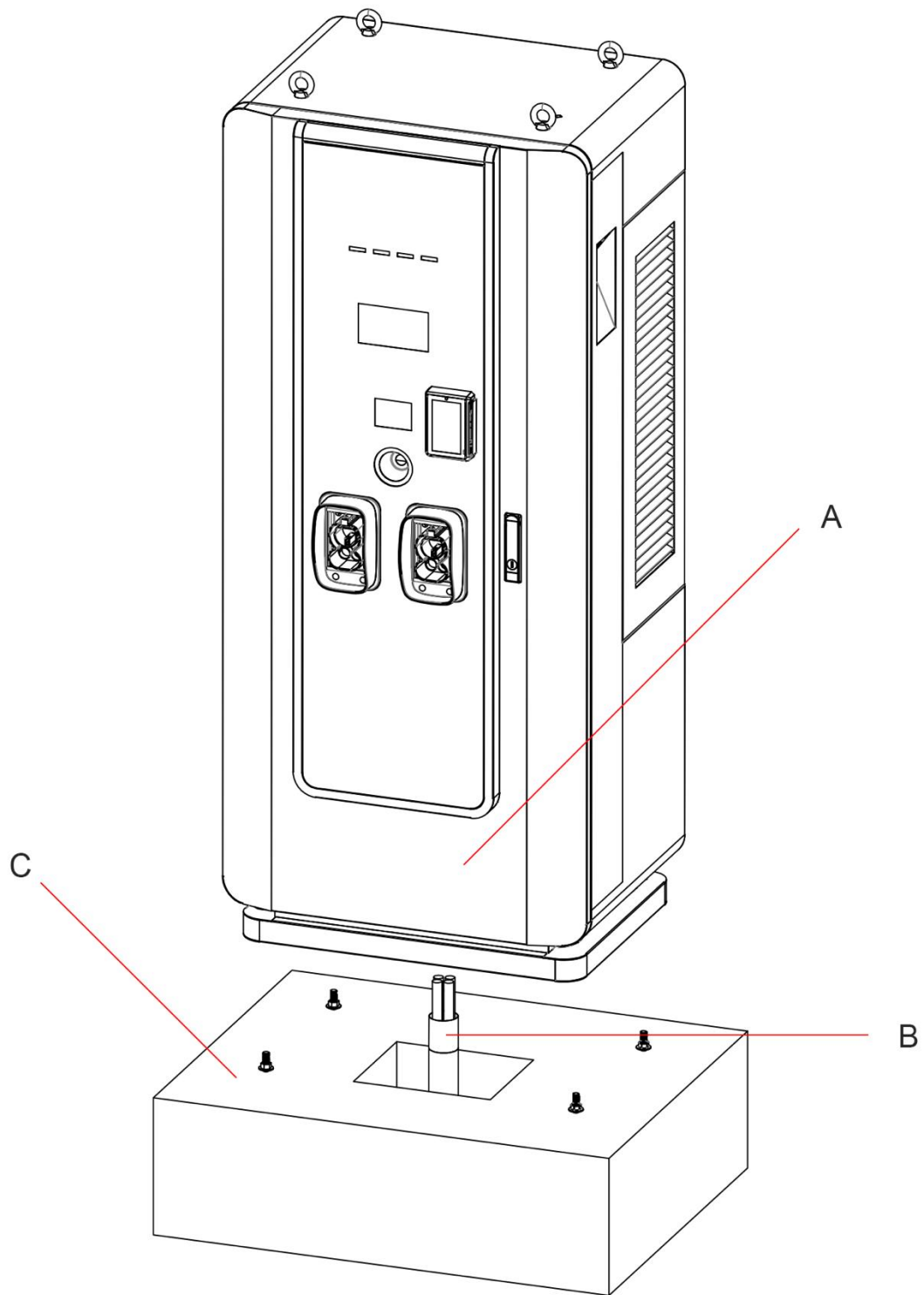

A. EV Charger

B. Cable

C. Concrete Pedestal

Placing the Cabinet to The Base

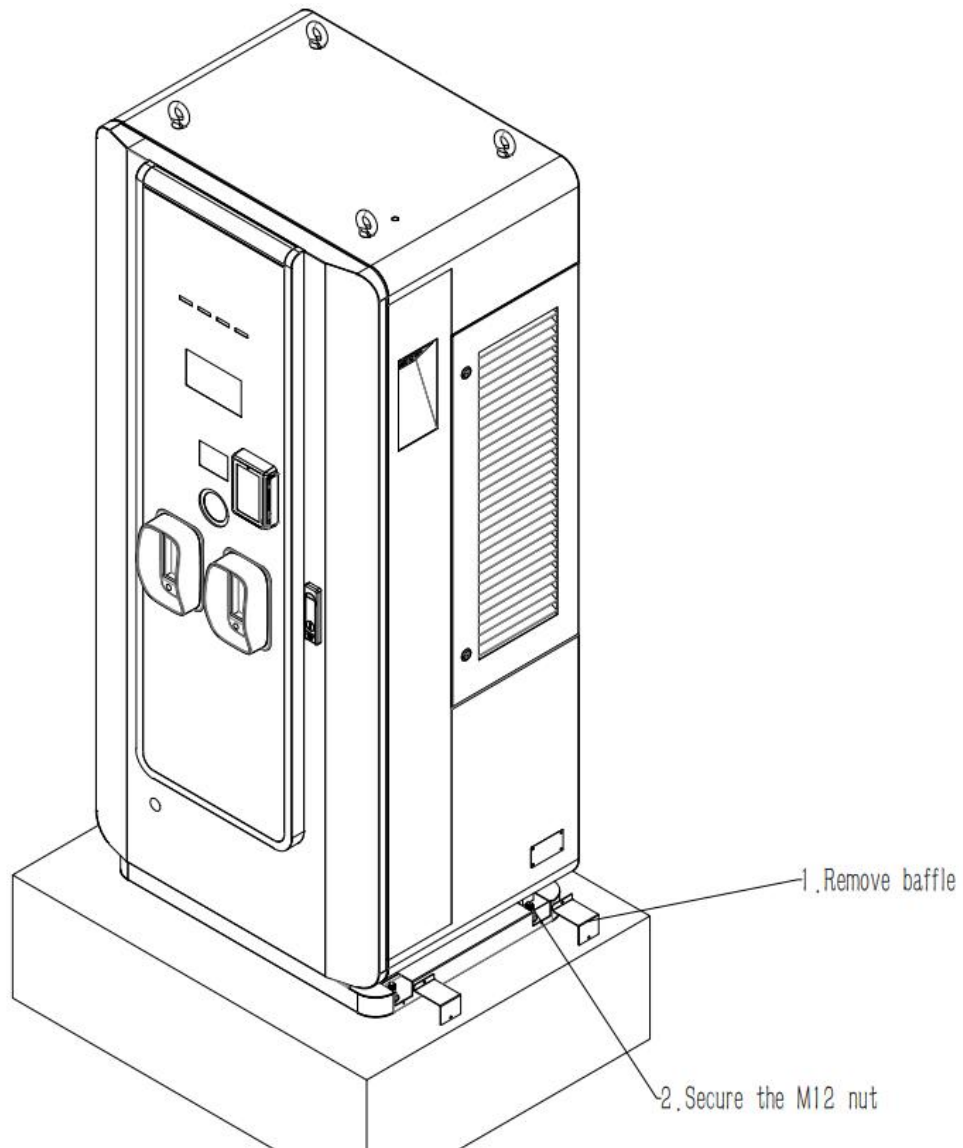

- Slowly lower the EV charger into place.
- Ensure the cable is exposed inside the cabinet along the envelope
- Align the cabinet holes with the bolt holes.
- Insert flat washers, spring gaskets, and M12 nuts.
- Tighten the nuts with a torque of 95.5Nm.

Connecting the Cable

Description: Different configuration versions require different wiring modes.

The reserved cable length is 0.7m.

- **Tools:** wire cutters, terminal / copper nose, terminal pressing clamp
- Remove 20mm of insulation at the cable end with a wire stripper.
- Crimp the cable end with suitable SC copper terminals.
- Connect the cable to the designated area as shown:
A/B/C for phase wire, N for neutral wire, PE for ground wire.
- The PE position is in the ground wire row at the bottom of the EV charger.
- Tighten the screws to a torque of 5Nm.

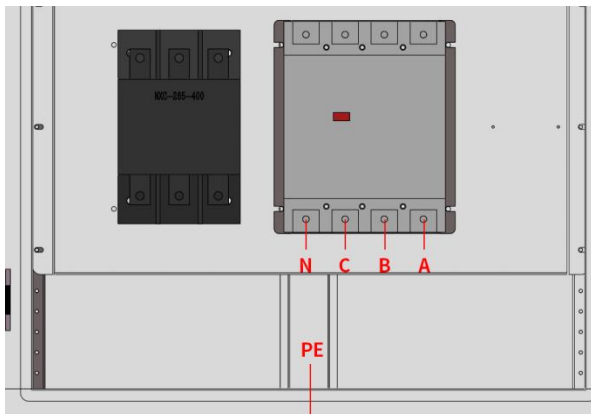

High Voltage Safety

Ensure that the main and auxiliary circuit switches of the EV charger are disconnected. Perform voltage detection to confirm no current is present in the wires and system.



Safety Note

For safety, it is recommended that the PE ground wire be left longer than the general phase wire to ensure the PE ground wire is connected first and disconnected last in case of an accidental collision.

Connecting Ethernet Cables

- **Tools:** network wire pressure clamp, RJ 45 connector, network cable
- **Procedure:**
 - Cut the network cable to the appropriate length for connection to the Ethernet interface.
 - Use the cable clamp to crimp the RJ 45 connector to the cable.
 - Connect the RJ 45 connector to the Ethernet interface.



Note:

This step is required only if the 4G network signal is poor or unavailable.

3.4 Installation and Adjustment

Installation and debugging are necessary final stages before the EV charger enters operation. The purpose is to check the safety and performance of the charging system for operational purposes.

Before Commissioning:

- Ensure all preparation, construction, installation, and connection tasks are completed.
- Connect the EV charger's input power supply and ensure the power charging capacity is ready.
- Assign a local project team technician for on-site assistance and power-on operation.
- Prepare a network cable connection if there is no 4G signal.
- Prepare a European standard pure electric vehicle for on-site trial charging tests.
- Arrange operation representatives for on-site guidance on charging operations.



Note:

The EV charger cannot be moved after debugging without negotiation.

Unauthorized movement voids the warranty.

For reinstallation to a new location, please contact our services in advance.

Once commissioned and verified, the EV charger can be put into operation.

IV.Direction for Use

4.1 System Startup

First Startup:

Execution by our professional or authorized personnel is required. For the first startup after installation in a new location, confirm that preparations are complete according to the "Installation Instructions". Contact the service engineer at least one week in advance to schedule installation, commissioning, and the on-site acceptance test (SAT). Do not complete the installation without performing the SAT.

Normal Startup:

Under normal conditions, connect the power supply, turn on the system power switch, and start the charging cabinet.



Caution:

- Do not touch the contact parts of the charging connector or immerse them in liquid to prevent electric shock.
- Do not place any objects in the charging connector or immerse it in liquid.
- Do not use the charger if there is any foreign object in the charging connector or if the contact is corroded or damaged.

4.2 Charging Operation

- Ensure the screen displays normally with no fault messages.
- Verify that the charger and its surroundings are in normal condition.
- If the screen displays any fault messages, do not use the charger and contact customer service for assistance.

Welcome Screen

System Initialization:

- Turn on the system power. The system will initialize upon startup.
- After initialization, the interface will display port status information.

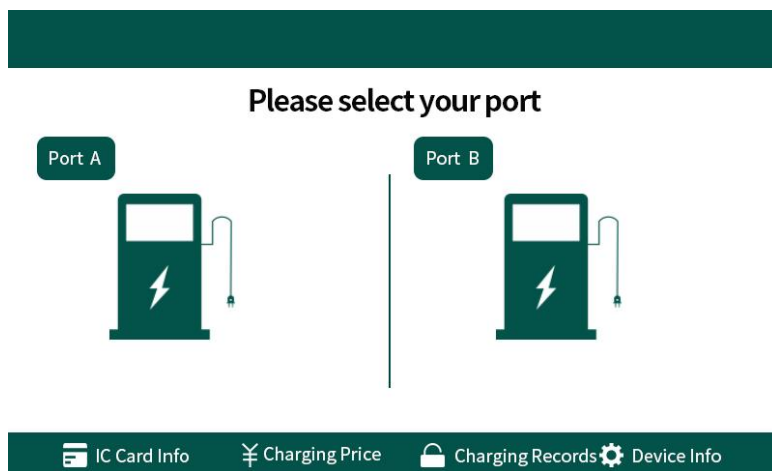

Port Selection

- Click the port labeled "Connected" to access the "Select Charging Method" screen.

As shown in the figure below:

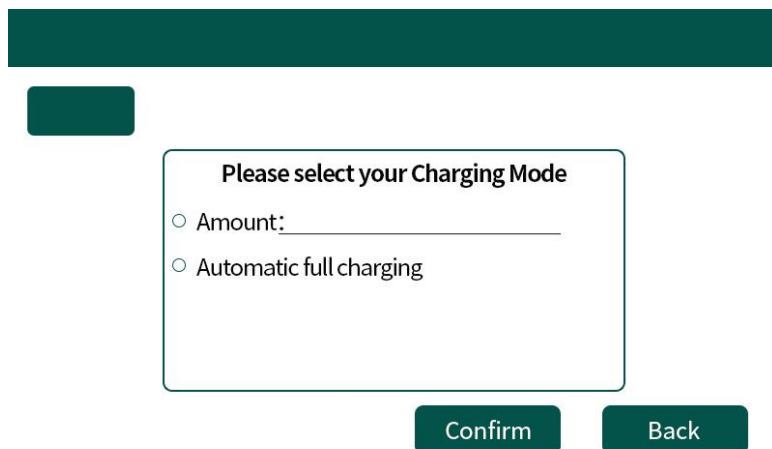

Swipe Card Charging

In the “Select Charging Method” screen, you can:

- Enter the desired amount and swipe a VISA or credit card on the POS terminal to start charging.
- Alternatively, click “Auto Full” and swipe the card to start charging.
- If the POS terminal is not configured, use the charging card provided by our company and swipe it in the designated area on the charger.

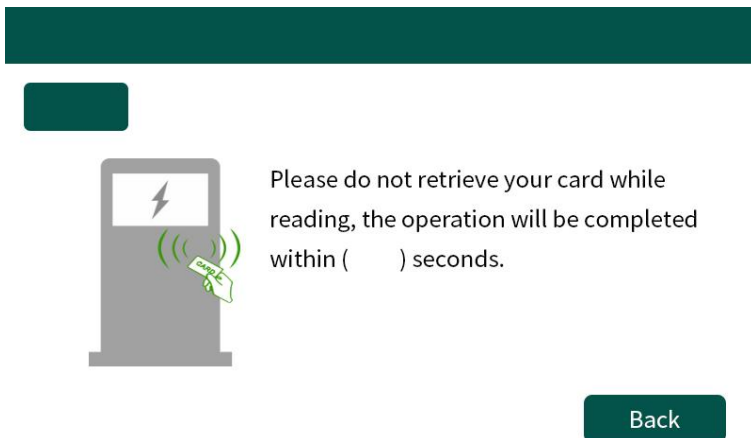

Scan Code Charging:

- Follow the on-screen instructions to scan the code and initiate charging.

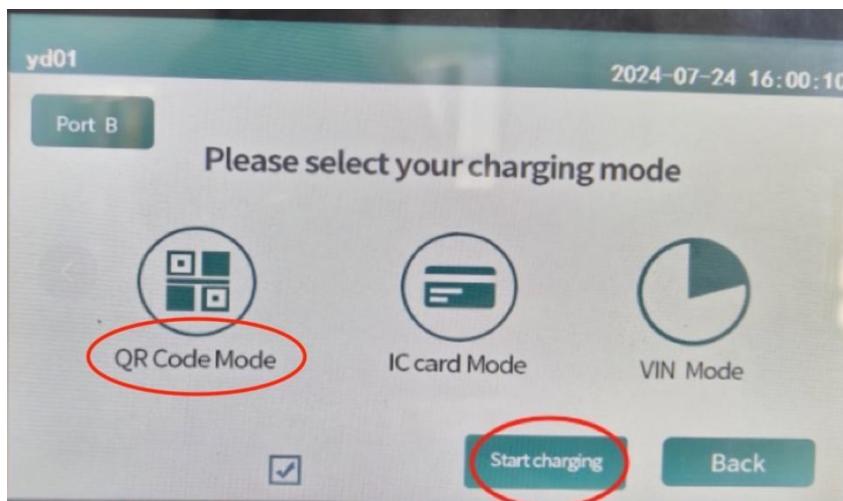

Charging Interface:

- Once charging starts, the interface will display relevant information about the connected port.
- Click “Fee Information” or “Battery Information” to view additional details.

As shown in the following figure:

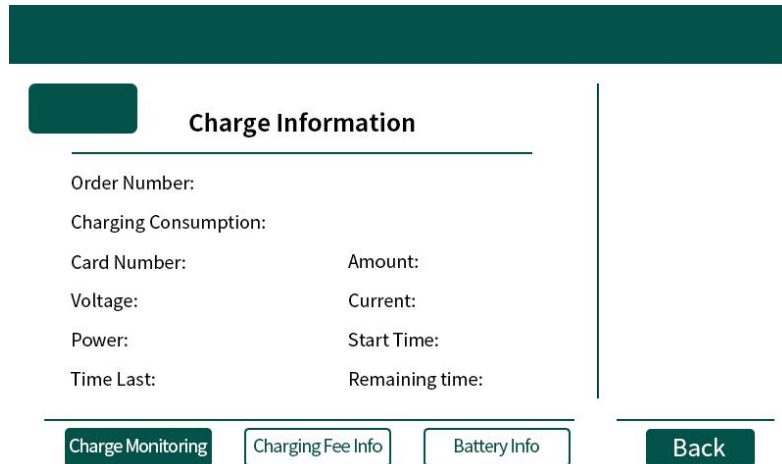

End of Charging

- To end charging, double-click the “End Charging” button on the charging interface.
- The interface will then display the settlement information for the connected port.

As shown in the following figure:

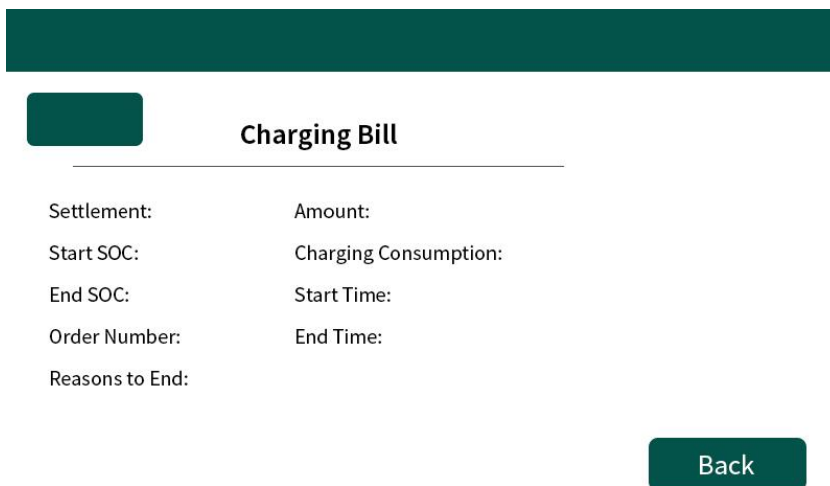

Attention



High Voltage:

Do not pull the connector directly when high voltage is present to avoid damage or serious injury.

Shutdown:

Operate shutdown via the screen or the APP.

Heat:

The EV charger surface may be hot during charging; do not cover vents.

Cleaning:

Do not clean the vehicle or the charger during charging.

Charging connector in place

- After charging is completed, return the charging connector and cable to the EV charger. Hang the charging cable on the hook and insert the connector head back into its seat.

- When the charging connector is connected to the vehicle, ensure the connector head is properly inserted into its seat to prevent dust or water ingress. To prevent the charging cable from causing accidents or tripping pedestrians, always hang the cable on the hook and insert the connector into its seat.

- After use, neatly wrap the cable to maintain its condition.

- To save energy, the EV charger screen will automatically turn off after about 18 seconds of inactivity. The charging connector is designed for 10,000 uses. After exceeding its service life or warranty period (whichever comes first), additional spare parts should be purchased.

- Damage to the charging connector caused by misuse, violence, or illegal operation is not covered under warranty.

- Any financial damages resulting from dangerous or violent operation shall be borne by the operator.

- The charging connector should not be subjected to violent impact, cable twisting, or illegal dragging.

- The operator is responsible for any failures caused by the charging connector being immersed in water without protection.

- Any failures or accidents resulting from exceeding the specified use conditions in this manual shall be borne by the user.

- Minors under the age of 16 are prohibited from operating the equipment. Any responsibility for incidents caused by minors shall be borne by the operator

Charging Abnormalities:

Charging abnormalities are not part of normal charging operations. Refer to this section only in case of abnormalities or misoperations.

- Emergency Stop: In case of an emergency, quickly remove the transparent protection cover and press the red "emergency stop" button. The system will cut off the power supply. Do not use the emergency stop button for normal shutdown.

- Undo the Emergency Stop: Rotate the emergency stop button clockwise to return to the charging state.

- Forced Connector Recovery:

-- Pulling out the charging connector during the charging process is very dangerous and strictly prohibited.

-- If the normal screen stop or swipe card stop operation cannot stop the charging process, press the emergency stop button.

-- Forcing the connector out may cause arc burns and the system will record the fault.

-- Click the confirm button to return to the charging shutdown state.

- ③ Double-click the green space above the screen center (as shown below)

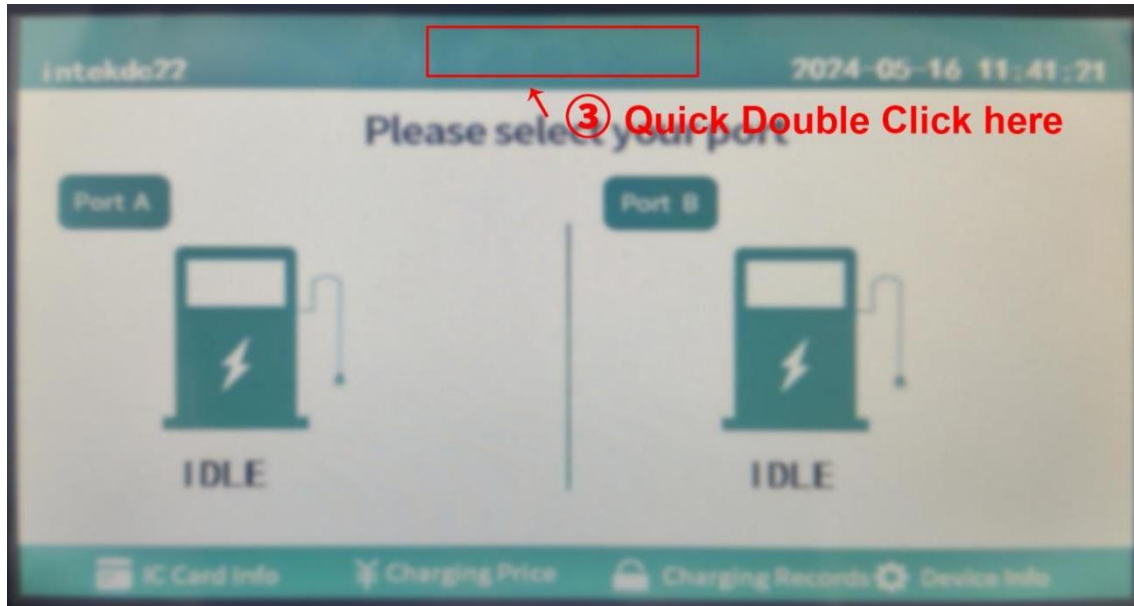

- ④ Click the blank of the input display box and enter 159357
- ⑤ Click "confirm" to enter the Settings interface;

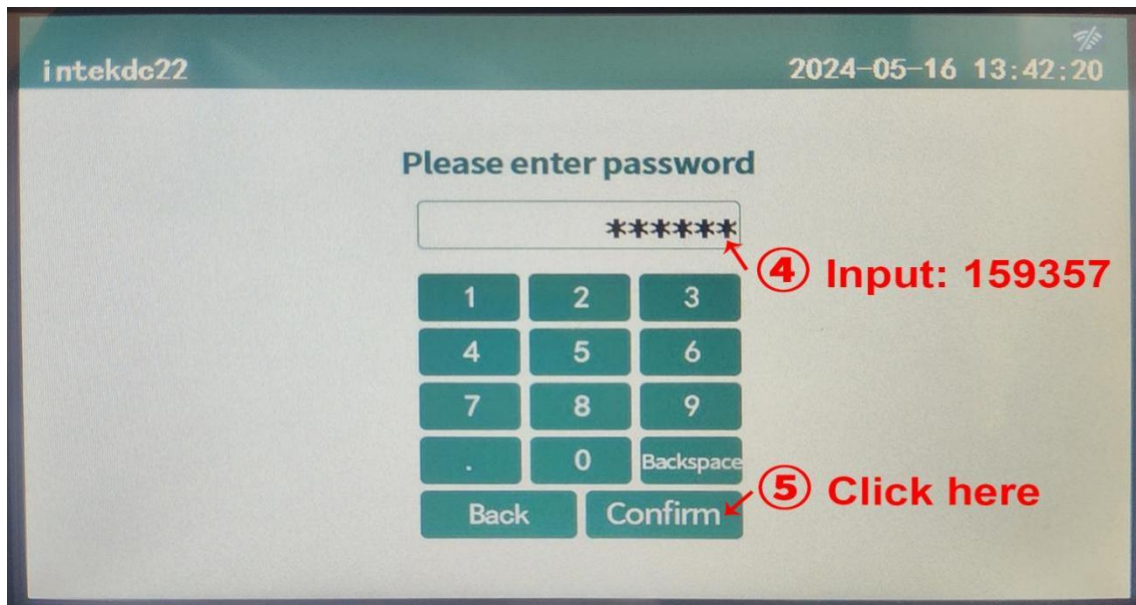

⑥ Set the Charger ID of OCPP (given by OCPP provider), and the url of Charger is `wss://dev.op.ma.az:8314/OCPP/intekdc22`, then enter `intekdc22`;

⑦ Set the platform to OCPP, if already set no click;

⑧ Click "Network Settings", after setting the chargerID and charging platform,

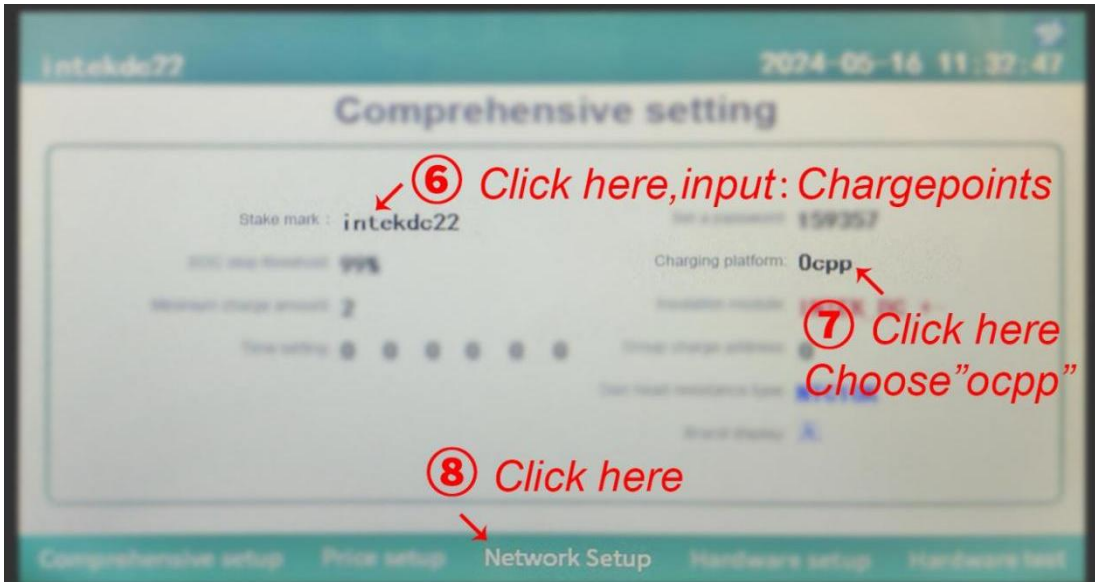

⑨ Click GPRS4G or ETH on the right of the screen, if it is already GPRS4G, no click;

⑩ Adjust OCPP Path: Chargepoints url to `wss://dev.op.ma.az:8314/OCPP/intekdc22`, enter `wss://dev.op.ma.az:8314/OCPP/`; then confirm;

*** Note: Note the double character keys on the keyboard (upper and lower characters), need to use Caps Lock to switch; for example: ':' needs to use Caps lock to input, do not enter ';', click Caps Lock again to switch to normal state before entering letters and numbers.**

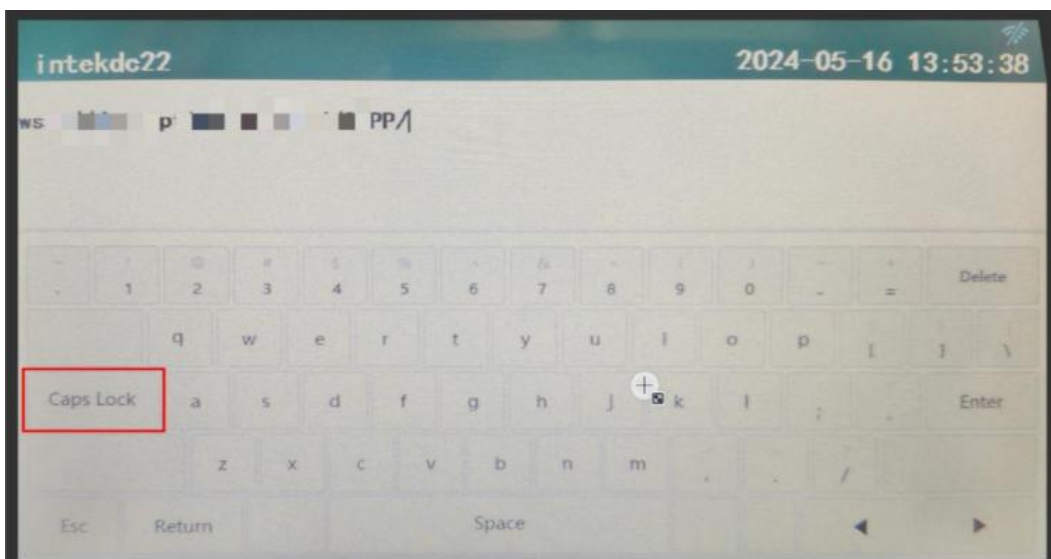

⑪ After returning to the interface, click the bottom left button of the screen to go back to the comprehensive Settings interface. Then, click the bottom left button again to return to the initial interface;

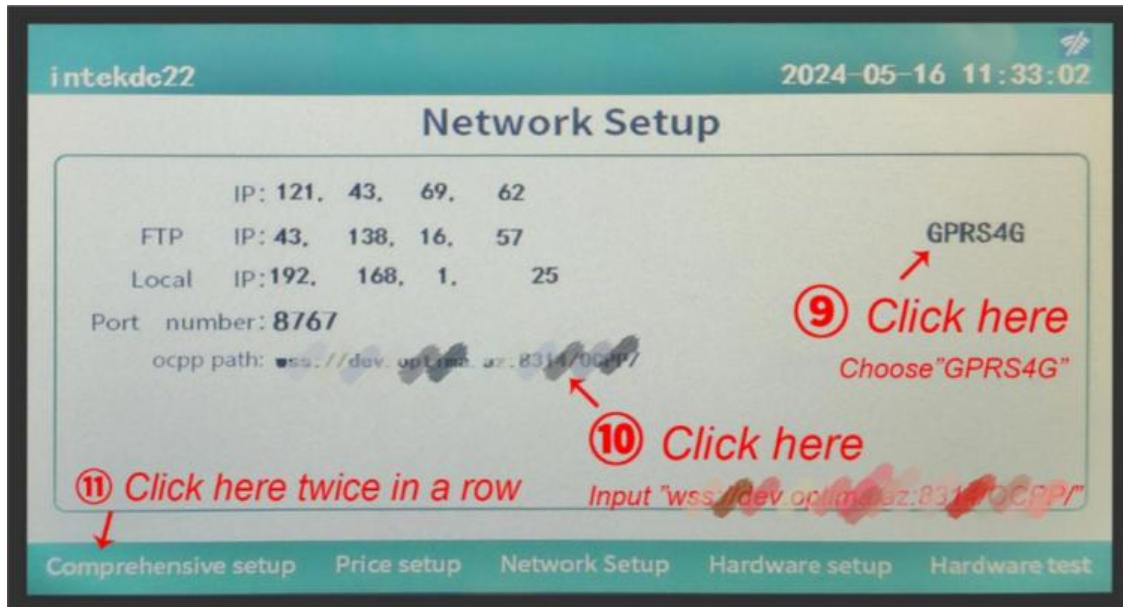

12 After returning to the initial interface, restart the charger and wait for 1~5 minutes, when the signal mark is displayed in the upper right corner of the screen, the communication is successful;

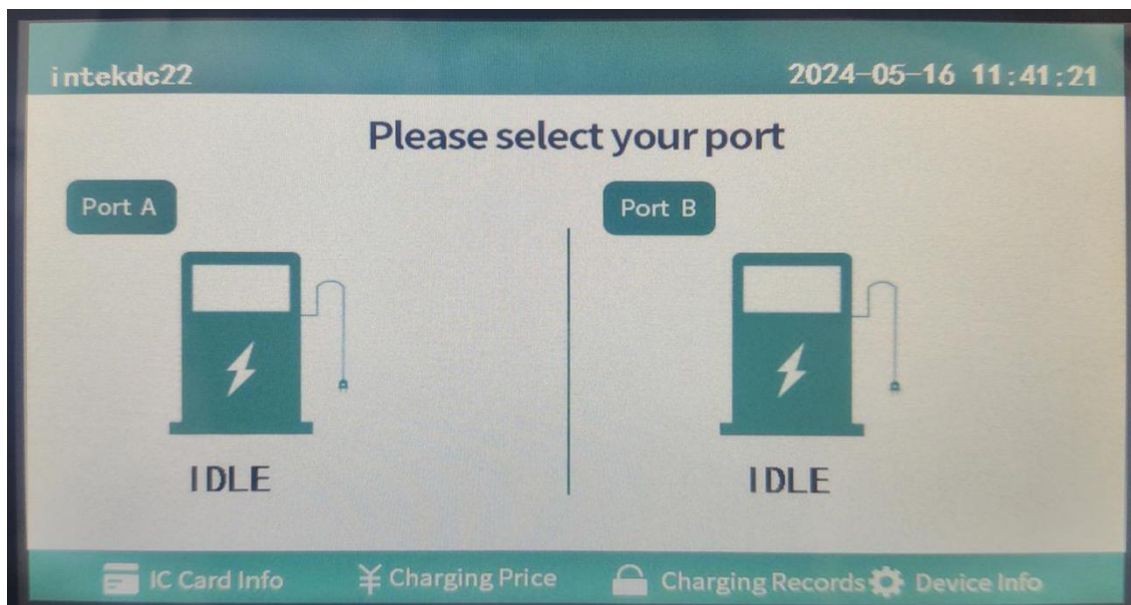

Ethernet cable setup:

- Insert the Ethernet network cable into the subnet cable slot on the OCPP control board (as shown below);
- Follow the same step as described for the SIM card mode;
- Change the Network Setup interface on the right side to ETH.

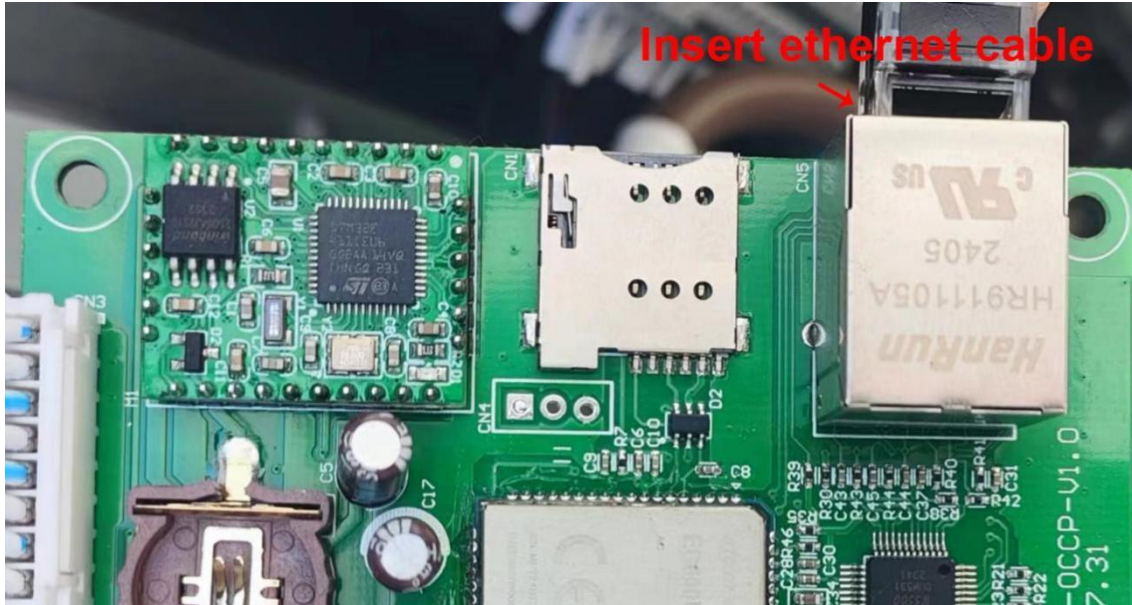

Click ETH on the right of the screen, if it is already ETH.

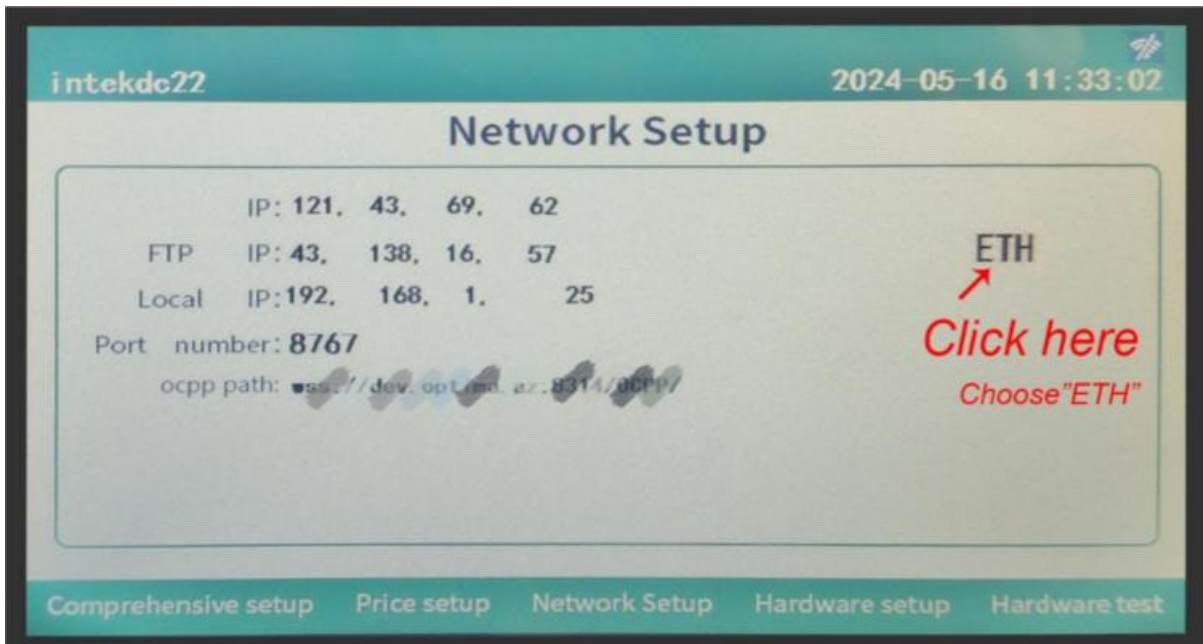

Then return to the original interface, restart and wait for its communication.

4.4 Operational Integration

- After startup, the charger connects with the cloud platform for remote management, diagnostics, and updates.

Integration with Existing Customer Operation Platforms:

- Our company supports integration with existing customer operation platforms through the OCPP protocol.

Please contact our sales or service engineer for assistance.

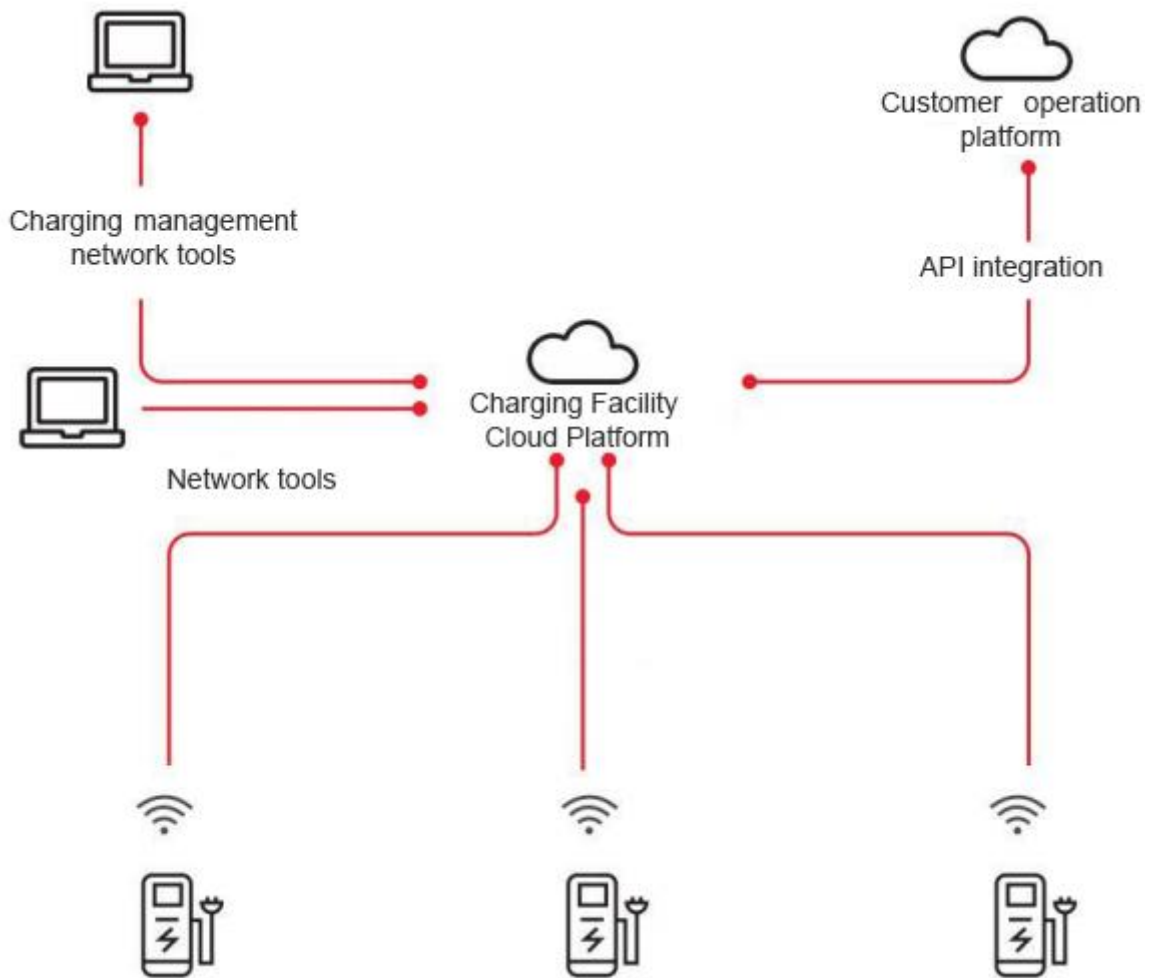

V.Maintenance Instruction

5.1 Daily Maintenance

Daily maintenance can keep the EV charger in a safe and stable and good state.

- Clean up the outer surface of the EV charger every two months
- Tighten the screw bolts at key parts every quarter
- Clean the air filter cotton and dust filter at least once every six months
- Test the leakage protection device once a year

Clean the Appearance

The outer surface of the EV charger is sprayed with powder, which needs to be kept in good state and maintain a beautiful image.

- Stop all the charging process, cut off the power supply, and plug in the charging connector
- Use wet, dust-free cloth to remove foreign matter and dust from the surface of the cabinet
- Only use strong stains with pH between 6 and 8, and then wash with clean water

Test the Electric Leakage Protection Device

Leakage protection is a crucial safety system that must be tested annually. Do not test the device during charging. Ensure all charging processes are stopped and the EV charger is disconnected from the vehicle.

- Open the front and side doors of the EV charger, avoid exposing the open cabinet to stormy weather.
- The EV charger must be in standby mode, which can be activated by touching the screen.
- Press the "Test" button for the leakage protection device:

- OK : The leakage protection device switches to the "off" position, stopping the EV charger. Reset the device by switching to the "on" position.

- Bad: If there is no reaction, disconnect the AC power supply, close the cabinet door, and do not use the charger until the leakage protection device is repaired. Contact our company or local supplier.

- Close the side and front doors of the EV charger.
- Record the time required for testing the leakage protection device annually.

Clean and Replace The Air Filter Cotton and Dust Filter

The EV charger is equipped with air filters to protect electronic components from dust. Clean the air filter and dust gauze at least once every six months.

- Always stop all charging processes before cleaning or replacement.
- Open the side door of the EV charger; avoid exposing the open cabinet to stormy weather.
- Unscrew the hand screws, remove the baffle, and the original air filter.
- Clean debris or dust from the filter and dust gauze.
- Install the cleaned filter, then replace the baffle and screws.
- - Close the side door.



Attention

Operating the EV charger without the air dust filter, or failing to replace it on time, will damage the device. Resulting faults are not covered under the warranty.

5.2 Advanced Maintenance

This EV charger is an Internet of Things (IoT) device with intelligent functions such as pre-charging self-inspection, daily regular self-inspection, and online monitoring of electrical parts and operating parameters.

- Under normal operation, only daily maintenance is required.
- In case of abnormal operation, please refer to the fault handling guidelines.

VI. Fault Treatment

6.1 Fault Identification

The EV charger installed in open places may fail due to various reasons, which should be roughly identified:

Improper Use of Fault

- Emergency stop button pressed
- Forced connector pulled

Charging System Failure

- See the list in the "Processing Methods" later

Electric Vehicle System Failure

- Abnormal system faults, abnormal voltage, abnormal insulation and other faults of electric vehicles will

lead to charging failures.

Man-made Fault Destruction

- the charging connector to crack, press, soak water
- The charging cable is rolled over and pulled by the wheel
- The charging cable is pulled and broken by the external force
- the EV charger is hit by a driving vehicle or a heavy object
- The door of the EV charger cabinet is opened abnormally
- Air duct blockage, etc

Note, human damage failure is not within the scope of warranty service

Natural Disaster Failure

- Earthquake damage
- Heavy rain flooding
- Lightning disaster
- An external fire

Note, the natural disaster failure is not within the scope of the warranty service

6.2 Treatment Method

No.	Display Status	Possible Cause	Suggest How to Deal With	Preliminary Treatment Party
1	Black screen, no touch response	AC input to the charging station is off	Check if the charger's input power supply is normal:ensure each phase of the two-phase input voltage is ~220V, with a line voltage of ~380V. Inspect for any leakage or short circuits in the input cable. If input is normal, try restarting. If the issue persists, contact our service personnel.	Customer operation and maintenance / Company service
2	Screen Flickering, white screen, incorrect display	Continuous 24-hour operation causing display freeze	Try restarting the power. If the issue persists, contact our service personnel for assistance.	Customer operation and maintenance/ Company service
3	Display: insulation detection fault	Insulation fault in the vehicle or EV charger	Replace the EV charger and attempt charging again. If the problem persists, it is likely an issue with the vehicle. If the fault does not recur, it indicates a problem with the EV Charger. Contact our service personnel for further assistance.	User/ Company service
4	Other issues not listed above	Various potential causes	Contact our service personnel for further assistance.	Company service

6.3 Maintenance Records

No.	Fault Description	Maintenance Method	Result	Attendant	Date	User
1						
2						
3						
4						
5						
6						
7						
8						

The above forms are used for maintenance records.

User Name (Company / Mr. / Ms.):

contact number:

installation time:

VII.After-sale Service

When the product becomes unusable, please contact us through your local operator. We will arrange for professional engineers to provide remote guidance until the issue is resolved.

Alternatively, you may email us with your requirements, and we will promptly provide the necessary assistance.



Email address: heshiyu.1988@163.com



240kW DC CHARGING

Installation and User Manual

Thank you for choosing our DC charging station product. To help you install and use the charging station correctly, please read this manual carefully and keep it safe. If you still have any questions about any of the contents, please contact our company in a timely manner and seek help. Our company reserves the right to modify the technical features and content in this manual.



















CATALOGUE

I. Security Statement	- 1 -
1.1 Safety Identification	- 1 -
1.2 Safety Warning	- 2 -
1.3 Liability Statement	- 2 -
II. Product Overview	- 4 -
2.1 Product Parameters	- 4 -
2.2 Functional Features	- 5 -
2.3 Product Description	- 7 -
III. Installation Instructions	- 11 -
3.1 Construction Preparation	- 11 -
3.2 Installation and Preparation	- 13 -
3.3 Installation Steps	- 16 -
3.4 Installation and Adjustment	- 21 -
IV. Direction for Use	- 22 -
4.1 System Startup	- 22 -
4.2 Charging Operation	- 23 -
4.3 OCPP Network Settings	- 28 -
4.4 Operational Integration	- 33 -
V. Maintenance Instruction	- 34 -
5.1 Daily Maintenance	- 34 -
5.2 Maintenance and Maintenance	- 35 -
VI. Fault Treatment	- 36 -
6.1 Fault Identification	- 36 -
6.2 Treatment Method	- 37 -
6.3 Maintenance Records	- 38 -
VII. After-sale Service	- 39 -

I.Security Statement

1.1 Safety Identification

	<p>Refer to Instruction Manual</p> <p>It typically signifies that user guide manuals or original documents must be kept properly for future use, and must not be damaged in any way</p>
	<p>General Warning</p> <p>Important security information that must be very carefully observed</p>
	<p>Dangerous Voltage</p> <p>Indicates situations where dangerous voltage must be handled with extreme caution</p>
	<p>High Temperature Warning</p> <p>Represents the burn hazard in high temperature areas or areas with high component temperatures</p>
	<p>Hazard of Injury Due to Equipment Weight.</p> <p>Indicates careful lifting and transport are required to avoid injury</p>
	<p>Prohibition Notice</p> <p>It means that entering the relevant area or performing the operations is prohibited</p>
	<p>Avoid Child Contact</p> <p>Indicates that the equipment should be kept out of reach of children</p>
	<p>No Smoking and Using Open Fires are Allowed</p> <p>Indicates prohibition of smoking and use of open flames near the equipment</p>
	<p>Personal Protective Equipment</p> <p>Indicates that the operations must be performed using clothing and / or personal protective equipment provided by the employer</p>
	<p>Ground Protection Connection Point</p> <p>Indicates the designated connection point for ground protection</p>
	<p>Allowable Temperature Range</p> <p>Indicates the range of temperatures within which the equipment can operate safely</p>
	<p>Direct Current</p> <p>Indicates the use of direct current(DC)</p>
	<p>Alternating Current</p> <p>Indicates the use of alternating current(AC)</p>
	<p>Positive Electrode of the Input Voltage</p> <p>Indicates the positive electrode for input voltage/current</p>
	<p>Negative Electrode of the Input Voltage</p> <p>Indicates the negative electrode for input voltage/current</p>
	<p>Note Content Identification Suggestions or Comments</p> <p>Indicates notes or suggestions for the content</p>

1.2 Safety Warning

The company's EV Chargers are designed and tested in strict accordance with the relevant national and international safety standards. However, the safety of power electronic equipment is not only affected by the quality of the equipment itself, but also highly related to handling, installation, trial operation, operation, maintenance, demolition and other operations. Incorrect use or misoperation will lead to the following risks:

- Risks of electric shock, short circuit, fire, explosion, and severe burns;
- Harm to the life and personal safety of the operator or a third party;
- Damage to the EV Charger or other property.

To avoid safety accidents, the following safety precautions should be strictly observed during installation and maintenance.

- All preparation, installation, movement, maintenance and disassembly, must be completed by professional and technical personnel. Unauthorized loading and unloading are prohibited.
- Professional and technical personnel must be qualified and trained or proven to have skills and knowledge in the structure and operation of EV Chargers;
- Read this manual completely and understand the relevant safety matters.

1.3 Liability Statement

Owner Responsibility

Requirements for Charging station owners and field operators:

- Run the charging station with full implementation of protective measures ensuring the correct installation and regular maintenance of protective facilities;
- Prepare an emergency plan to handle emergencies effectively;
- Prepare the installation site according to the requirements described in this manual;
- Ensure sufficient space for passage and maintenance of the EV Chargers;
- Assign a person responsible for safe operation and overall coordination;
- Understanding that unauthorized changes can affect the operation authorization or warranty.

Disclaimer

The Company shall not be liable for accidents or damage caused by:

- Human factors or abnormal working environments;
- Faults and damage caused by not following the instructions;
- Damage due to poor transport after delivery;
- Normal wear and tear, rupture and immersion dyeing;

- Products not belonging to the company (eg: counterfeit goods);
- Unauthorized disassembly, repair, or modification
- Damage due to other non-resistance (such as flood, fire, lightning strike, typhoon, earthquake, abnormal voltage);
- Use beyond the service life not covered by warranty;

II.Product Overview

2.1 Product Parameters

No.	Product	Dc Charger For Electric Vehicles
1	Input Line System	Three-phase five-wire 3P + N + PE
2	Input Voltage	380V/400V AC \pm 20%, 50Hz/60HZ
3	Rated Power	240kW DC
4	Power Factor	~0.99 (Full load)
5	Output Voltage	200—1000VDC
6	Constant Power Area	300—1000VDC
7	Maximum Current of Single Connector	250A DC
8	Cabinet Dimensions	800mm*630mm*1830mm (excluding Connector holder)
9	Levels of Protection	IP54
10	The charging Cable Length	5m
11	Noise	\leq 75dB
12	Working Temperature	-20 $^{\circ}$ C~+50 $^{\circ}$ C
13	Storage Temperature	-20 $^{\circ}$ C~+70 $^{\circ}$ C
14	Working Humidity	Relative humidity 5% to 95%
15	Working Altitude	Up to 2000m (above 2000m needs special consideration)
16	Gas Medium	Should avoid explosive, corrosive and harmful gases and conductive media
17	Open Installation	Suitable for all-weather open-air installation
18	Verticality	Mounting vertical inclination should not exceed 5 $^{\circ}$
19	Cable Entry	Bottom entry for cables
20	Cable Outlet	The upper cable outlet of the cabinet is designed to be waterproof and resistant to immersion, rain, and snow. It also prevents tripping hazards for pedestrians and vehicles.

2.2 Functional Features

Safety

- Unique safety mechanisms including pre-charging protection, main circuit safety detection and remote diagnosis management
- Basic protection measures such as lightning protection, overvoltage, overcurrent, short circuit, connection fault, and emergency stop
- Comprehensive charging protection functions and mechanisms that effectively guarantee the safety of personnel, prevent overcharging, and ensure operational safety

Intelligence

- The terminal EV Chargers and the cloud platform intelligent Internet of Things can perceive more than 100 underlying operating parameters in real time
- Features remote diagnosis, remote reset, and remote upgrade capabilities.

Reliability

- Independently designed hardware and software, from circuit boards to system architecture, and from embedded software to cloud platform, ensuring high consistency, compatibility and stability
- Performance Metrics such as current accuracy, voltage accuracy, leakage protection accuracy, ripple harmonic, and standby power consumption exceed industry averages.
- Utilizes international first -line brand components for high system reliability. The wind duct maze design effectively prevents issues such as splashes and accidental collisions, making it suitable for installation in urban public parking lots and roadside parking spaces.

Convenience

- Flexible networking options with both wireless and wired communication modes.
- Anti-sunlight liquid crystal display with a user-friendly interactive interface
- Open communication protocol supporting code scanning charging, API services, and energy demand response

Interactive Function

- All charging stages include intuitive and friendly illustrations and text prompts on the screen.
- The screen features an anti-sunlight display and is ergonomically arranged for ease of use.

Measurement function

- DC metering function with an accuracy level of 1.0.

Communication Function

- Supports Ethernet access and 4G wireless communication networking.

Payment Function

➤ The EV Charger provides charging consumption time and quantity information to the operation background which centrally controls the charging strategy. The integrated system supports various payment methods such as card swiping, code scanning, and mobile app payments.

- Customizable optional POS machine supporting VISA and international credit card payments.

Self-Test and Self-Repair Function

➤ During power operation, the EV Chargers conducts a self-check of the equipment's working environment, power supply, data storage space.

➤ Fault information is displayed on the screen, recorded, and stored in the superior monitoring and management system.

➤ Automatically monitors the operation of key components, including but not limited to charging connectors connection self-test, contactor adhesion self-test, and power unit state self-test.

Remote Internet of Things Function

➤ The EV Chargers connects with the device cloud platform to monitor numerous parameters in real time providing comprehensive remote diagnosis, remote service, and remote upgrade service

Diagnostics include checks for whether the charger cabinet door is opened, whether the emergency stop button is pressed, whether the AC contactor is disconnected, whether the vehicle is connected, whether the connector head temperature is too high, and whether the insulation test is normal.

2.3 Product Description

Product Appearance

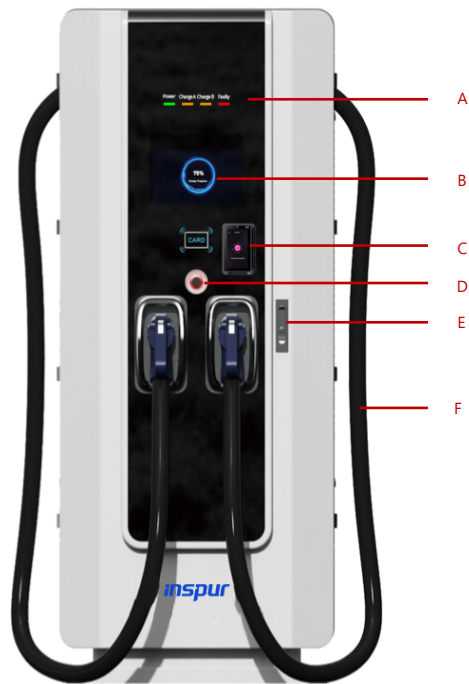

A.LED Indicator Light

B.User Interface Display Screen

C.POS Machine (Configuration Options)

D.Emergency Stop Button

E.Cabinet Lock

F.Charging Cable

Note: Due to the version iteration, there may be some differences between photos and physical objects.

Inner Structure

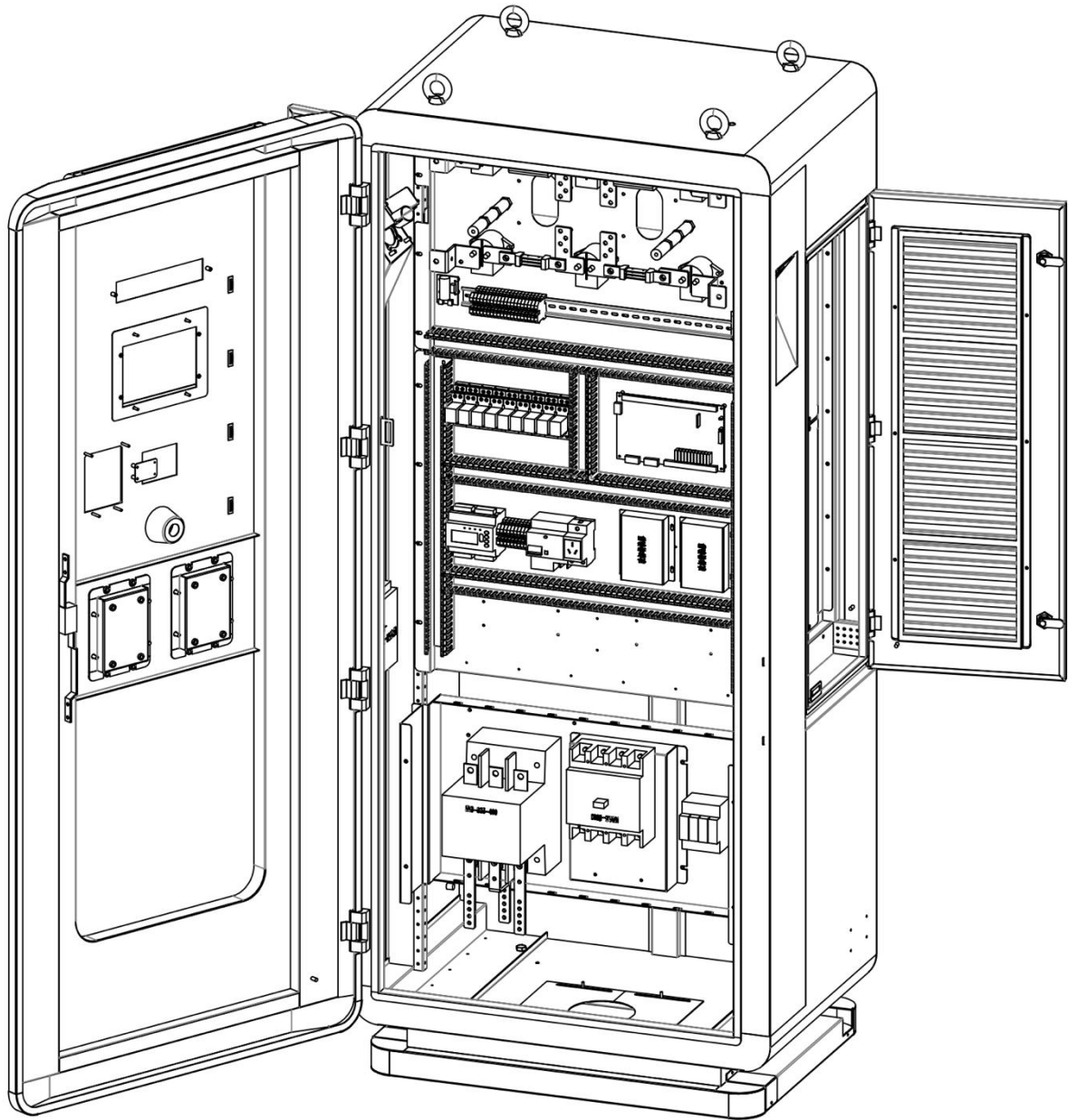

Note: Due to the version iteration, there may be some differences between photos and physical objects.

Space Requirement

To ensure the safe and reliable operation and convenient maintenance of the equipment, sufficient space for installation must be reserved.

The space requirement during installation is 1800mm * 1680mm, calculated as follows:

- **Dimensions(W * D * H):** 800mm * 630mm * 1830mm (excluding connector holder)
- **Front Side Clearance:** Reserve 1000mm to ensure the normal operation of the front door switch and smooth functioning.
- **Left Side Clearance:** Reserve 500mm to allow for normal operation of the front door and smooth functioning.
- **Right Side Clearance:** Reserve 500mm to enable normal operation of the side door , maintenance space for the charging module, and smooth airflow into the air inlet.
- **Rear Clearance:** Reserve 50mm to ensure that the side doors on both the left and right are not obstructed.

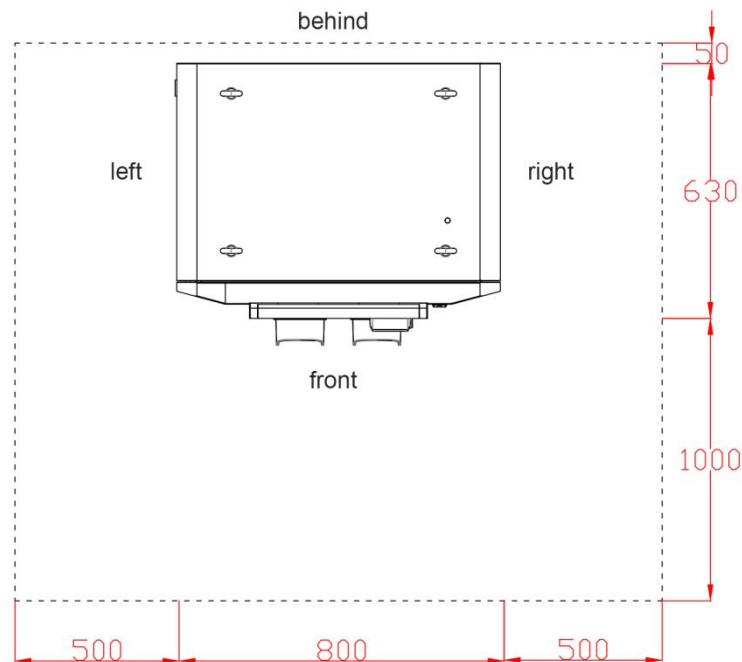

Ventilation Requirements

The EV Chargers converts AC to DC to charge electric vehicles. During this conversion process, some energy is lost as heat, necessitating efficient heat dissipation. Therefore, it is essential to ensure that the installation space has open and continuous airflow, and that the main air inlet and outlet paths are not blocked. It is not recommended to install the charger in a confined space without ventilation. The product's air inlet is located on the right side of the screen, and the air outlet is on the left side.



Attention

Ensure Unobstructed Airflow:

Preventative measures should be taken to keep the air ducts clear.

Avoid any obstructions, such as snow or foreign objects, from blocking the air inlet and outlet.

III. Installation Instructions

3.1 Construction Preparation

About the Construction

The construction phase includes all tasks necessary to prepare the installation site for placing and connecting the EV charger. The following conditions must be met to begin the construction phase:

- All engineering preparations are complete
- All necessary permits have been obtained
- The grid can be connected

Cable Entry

The cable should enter through the bottom of the EV charger.

Infrastructure Projects

The suitability of the installation site is related to the surface type of the infrastructure construction.

Foundation Requirements

-Indoor Installation: A foundation is not required if the equipment is installed indoors or in other high and dry places. The ground smoothness error must not exceed $\pm 1.5\text{mm}$ per square meter, and the ground strength at the installation position should be at least C30.

-Outdoor Installation: When installed outdoors or in areas prone to water accumulation, a cement or tank steel base must be used. The cement base should be 200mm high, with a recommended depth below ground of at least 500mm. Four M12 stainless steel bolts should be embedded in the installation surface, extending $40 \pm 3\text{mm}$ above the ground. The foundation design should be tailored to the actual site conditions.

-Instructions:

- Excavate a pit at the installation site as specified.
- Ensure the cable can enter through the embedded pipe, with an aperture of at least 100mm.
- Pour the concrete foundation as illustrated.
- Ensure the EV charger's base height is at least 200mm to reduce flooding risk.
- Expose 0.7m of cable length above the foundation for internal wiring.

Fill the foundation's inner and outer holes with sand and stone, and seal the inlet holes with fireproof mud to prevent small animals from entering the equipment.

Base Hole Position and Installation Method

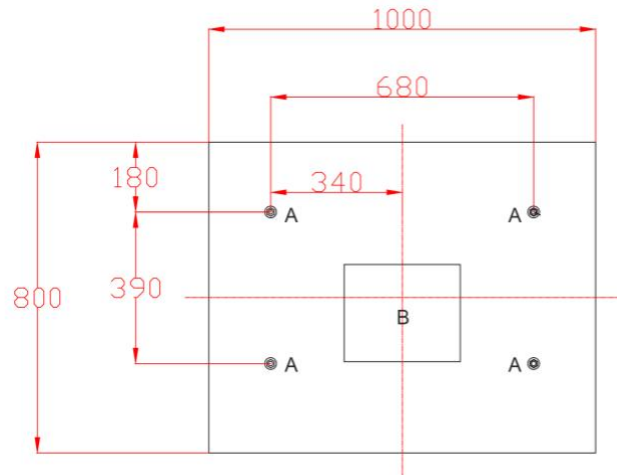

- Figure A: Embed four M12 stainless steel bolts.(screw anchor)
- Figure B: Identify the power cable entrance location.
- Exposed cable length for internal wiring is 0.7M

Cable Protection Requirements

- **Cable Type:** three-phase and five-wire system (3P + N + PE),
Verify if shielding is required based on local laws.
- **Shielding Layer:** Connect both ends of the shielding network with the PE safety ground wire if present.
- **Cable Diameter:** Determined by the contractor or electrical engineer based on power, distance, and industry standards.

- **PE Safety Ground Wire:** Should match the N wire model size.

- **Recommended Cable Cross-sectional Area:**

-For 240kW: YJV 4 * 185 + 1 * 95

- The cable must comply with national and local standards.

- Each EV charger must have independent open and leakage protection.

Network Connection Requirements

-**Standard:** 4G wireless communication module integrated with the EV charger. Users should prepare a SIM card. If no 4G signal is available, use a standard wired Internet connection.

-Wired Connection Requirements:

--**The RJ 45 Ethernet:** 8P + PE, shielding wire.

-- **Recommended Length:**

Up to 75m, refer to HELUKAT 600E.

For lengths over 75m, an engineering scheme is required.

--The Minimum Bandwidth:

Uplink: 128 kbps

Downlink: 4 Mbps

--Connection Dependability: 99.9%

3.2 Installation and Preparation

Transport Loading and Unloading

- Handle heavy equipment with care.
- Use appropriate load-bearing equipment such as forklifts, cranes, or towing trucks, operated by professionals.
- Avoid dumping or crashing the equipment.

Keep the device upright, with a tilt angle not exceeding 30 degrees.

Arrival Inspection:

- Check for package damage and label correctness upon arrival. If any abnormality is found, inform the carrier, take photos, and collect evidence. Sign the documents and contact the manufacturer for further action.
- Verify that product accessories and accompanying documents are complete according to the packing list.
- Inspect the product visually for any signs of collision, scratches, cracks, corrosion, damage, or paint peeling.
- Check the charging connector for any abnormalities such as crushing, rust, damage, or loose connections.
- Sign documents, save records, and distribute or transfer them to related parties.

On-site Confirmation

- Ensure that the site's altitude, coordinates, temperature, humidity, ventilation, load-bearing capacity, installation position, maintenance space, and power supply meet the equipment's requirements.
- Confirm that the on-site 4G signal strength is good (signal strength greater than -85 dBm, or above 50% full grid strength as observed on a mobile phone).
- Verify that all necessary licenses are in place.
- Confirm that the project preparation work is complete and the power grid connection is available.
- Avoid starting installation if construction is ongoing at the site to prevent damage from building materials, dust, paint, muck, or litter. It is recommended to install the EVcharger after construction is completed.

For short-term or long-term storage, store the equipment in a dry, well-ventilated indoor place, away from high temperatures, humidity, dust, metal powder, and corrosive gases.

Important Notes:

- Due to the complexity and danger of EV charger installation, only qualified professional and technical personnel should perform the installation according to this manual.
- Prepare and check relevant tools and devices, ensure personal protection, and wear protective gloves during installation to prevent injuries from metal parts. Use appropriate lighting devices if needed.
- Ensure all switches associated with the equipment are in the off state (when repairing or replacing spare parts, ensure the equipment is well grounded).

Use professional tools to confirm the power supply is disconnected, with no power input and output to the equipment. Ensure each charger has independent protection and disconnection conditions, and use a special power interface with proper grounding. Fire and neutral wires must not meet. Turn off the power and take reasonable measures to prevent the power switch from closing automatically.

Installation Tools

Name	Main Role	Quantity
Multimeter	Check Electrical Connections and Parameters	1 pc
Electric Impact Drill	Drill Holes	1 pc
Impact Bit (Φ 16mm)	Drill Bit	2 pcs
Band Tape	Measure	1 pc
Leveling Instrument	Measure	1 pc
Slotted Screwdriver	Open	1 pc
Plier	Open	1 pc
Wire Stripper	Remove Insulation Sheath	1 pc
Terminal Crimping Pliers	Crimp Terminals	1 pc
Diagonal Pliers	Cut Cables	1 pc
Adz-eye Hammer	Unpack, Tap and Adjust	1 pc
Transport Equipment	Move and Hoist EV Chargers	1 set
PVC Insulation Tape	Insulate Connections	1 roll
Personal Protection Tools	Ensure Operator Safety and Health	1 set/ personnel
Multi-Function Crowbar	Remove Wooden Box	1 pc

Basic Tools

Order Number	Nut /Bolt	Tool	Installation Site
1	M12 Hexagon Nut	19 # Tools Included With The Charger	Base Installation (fixed to cement base)
2	M8 Inner Hexagon Bolt	6mm Inner Hexagon Spanner	Input Ground Wire, ABC Phase Power Input, N Wire Installation
3	M10 Inner Hexagon Bolt	8mm Inner Hexagon Spanner	240kW Cable, ABC Phase Power Input, N Wire Installation

Installation, Repair, and Replacement of Spare Parts

Safety Precautions:

- Live work is strictly prohibited
- Unauthorized disassembly is strictly prohibited.
- Ensure equipment operation safety.
- Follow the sequence PE ground wire > zero wire > phase wire for power supply line access.
- All operations must comply with the relevant safety standards

Post-installation, Repair, and Replacement

- Perform acceptance and testing according to installation and maintenance requirements.
- Organize and collect tools, restore the internal switch to the working state.
- Lock the safety door to maintain equipment safety.

3.3 Installation Steps

Receiving the Goods

EV charger products can be delivered by the transportation company to the destination warehouse or the agreed location. For standard orders, the factory is not responsible for delivering the equipment to the final installation point. Prepare personnel and equipment for unloading and transfer at the receiving site.

Removing the Packaging

Use a multi-functional crowbar to remove the outer packaging, and use scissors or an art knife to remove the inner packaging.

Installation Preparation

- Open the side cover plate of the base, release the clamp cylinder, open the stack plate screw, etc.
- Unscrew and keep the screws on the base side cover plate.
- Remove and safely store the side cover plates and the front door of the EV charger.
- Open the front door of the EV charger
- Check for any abnormalities such as loose threads or parts.
- Reattach the side door and front door in sequence.
- Unclip the bolts securing the cabinet to the stack plate.

Placing the Equipment in Position

Move the equipment to the pre-made concrete base using one of two methods:

- 1: Lift the EV charger into position using optional lifting rings.
- 2: Use a lifting forklift to carry the EV charger into place.



High Voltage Safety

Ensure that the main and auxiliary circuit switches of the EV charger are disconnected. Perform voltage detection to confirm no current is present in the wires and system.



Warning

Handling the EV charger after delivery is not covered under warranty. Handle with care during transportation and installation.

Handling EV Charger

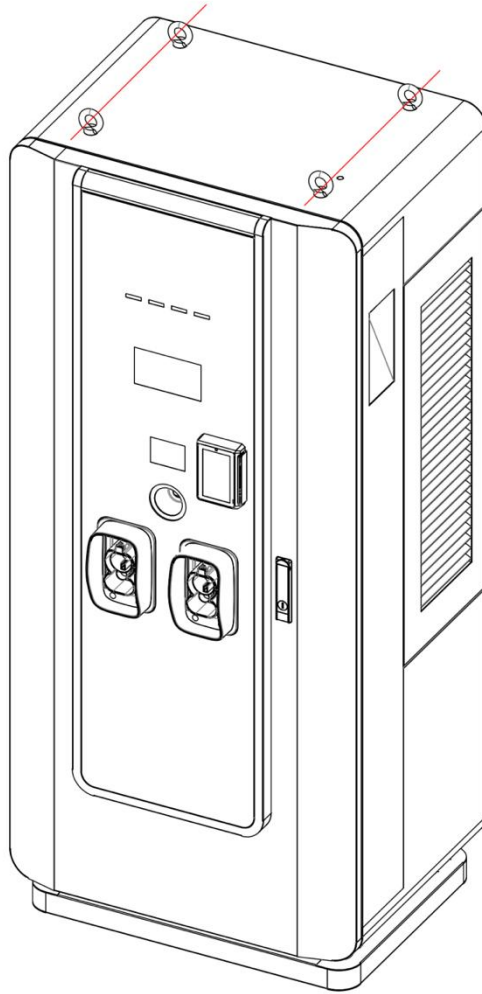

- Open the base-side cover plate
- Use the forklift truck to pass through the designated red line position as shown
- Carefully move the EV charger to the installation position

Locking the equipment

Preparation

- Tool: 19# wrench (for fixing M12 hexagon nuts).
- Raise the EV charger by about 0.5m and place it above the installation position.
- Pass the traction power cord through the cable envelope.

Placing the Cabinet to the Base

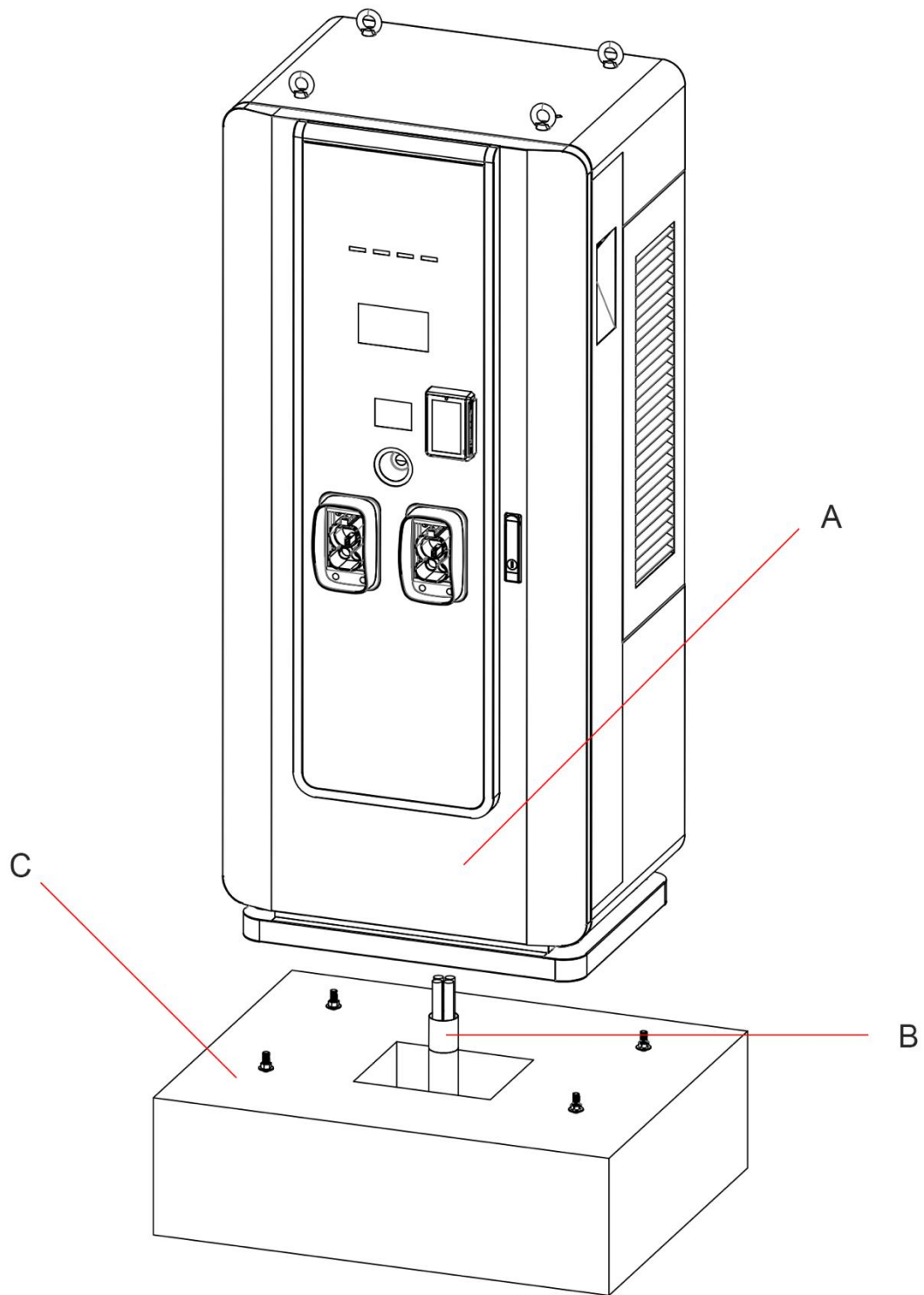

A. EV Charger

B. Cable

C. Concrete Pedestal

Placing the Cabinet to The Base

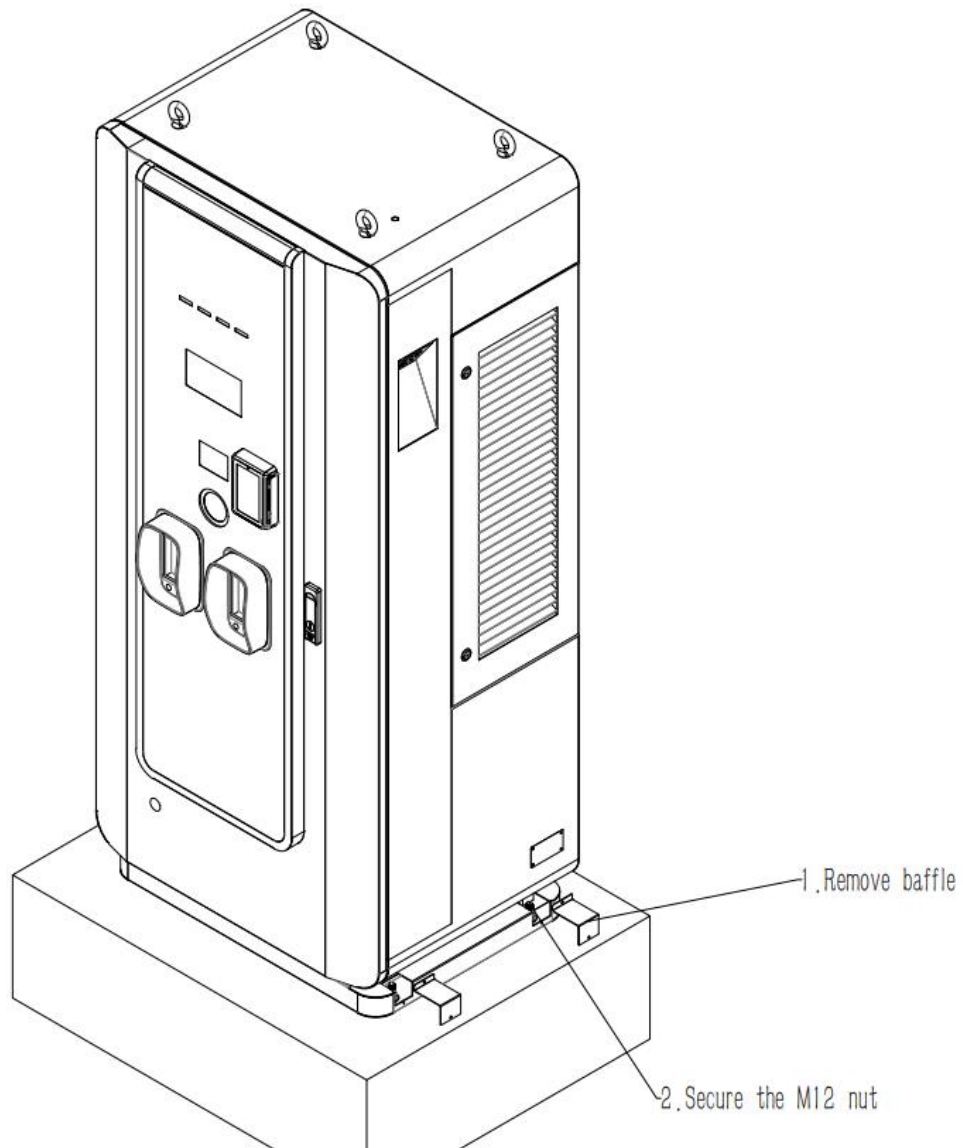

- Slowly lower the EV charger into place.
- Ensure the cable is exposed inside the cabinet along the envelope
- Align the cabinet holes with the bolt holes.
- Insert flat washers, spring gaskets, and M12 nuts.
- Tighten the nuts with a torque of 95.5Nm.

Connecting the Cable

Description: Different configuration versions require different wiring modes.

The reserved cable length is 0.7m.

- **Tools:** wire cutters, terminal / copper nose, terminal pressing clamp
- Remove 20mm of insulation at the cable end with a wire stripper.
- Crimp the cable end with suitable SC copper terminals.
- Connect the cable to the designated area as shown:
A/B/C for phase wire, N for neutral wire, PE for ground wire.
- The PE position is in the ground wire row at the bottom of the EV charger.
- Tighten the screws to a torque of 5Nm.

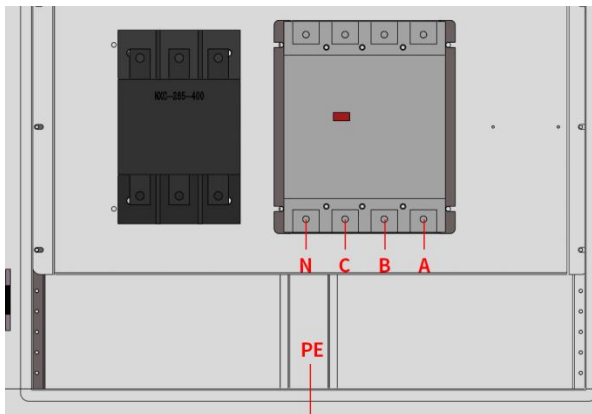

High Voltage Safety

Ensure that the main and auxiliary circuit switches of the EV charger are disconnected. Perform voltage detection to confirm no current is present in the wires and system.



Safety Note

For safety, it is recommended that the PE ground wire be left longer than the general phase wire to ensure the PE ground wire is connected first and disconnected last in case of an accidental collision.

Connecting Ethernet Cables

- **Tools:** network wire pressure clamp, RJ 45 connector, network cable
- **Procedure:**
 - Cut the network cable to the appropriate length for connection to the Ethernet interface.
 - Use the cable clamp to crimp the RJ 45 connector to the cable.
 - Connect the RJ 45 connector to the Ethernet interface.



Note:

This step is required only if the 4G network signal is poor or unavailable.

3.4 Installation and Adjustment

Installation and debugging are necessary final stages before the EV charger enters operation. The purpose is to check the safety and performance of the charging system for operational purposes.

Before Commissioning:

- Ensure all preparation, construction, installation, and connection tasks are completed.
- Connect the EV charger's input power supply and ensure the power charging capacity is ready.
- Assign a local project team technician for on-site assistance and power-on operation.
- Prepare a network cable connection if there is no 4G signal.
- Prepare a European standard pure electric vehicle for on-site trial charging tests.
- Arrange operation representatives for on-site guidance on charging operations.



Note:

The EV charger cannot be moved after debugging without negotiation.

Unauthorized movement voids the warranty.

For reinstallation to a new location, please contact our services in advance.

Once commissioned and verified, the EV charger can be put into operation.

IV.Direction for Use

4.1 System Startup

First Startup:

Execution by our professional or authorized personnel is required. For the first startup after installation in a new location, confirm that preparations are complete according to the "Installation Instructions". Contact the service engineer at least one week in advance to schedule installation, commissioning, and the on-site acceptance test (SAT). Do not complete the installation without performing the SAT.

Normal Startup:

Under normal conditions, connect the power supply, turn on the system power switch, and start the charging cabinet.



Caution:

- Do not touch the contact parts of the charging connector or immerse them in liquid to prevent electric shock.
- Do not place any objects in the charging connector or immerse it in liquid.
- Do not use the charger if there is any foreign object in the charging connector or if the contact is corroded or damaged.

4.2 Charging Operation

- Ensure the screen displays normally with no fault messages.
- Verify that the charger and its surroundings are in normal condition.
- If the screen displays any fault messages, do not use the charger and contact customer service for assistance.

Welcome Screen

System Initialization:

- Turn on the system power. The system will initialize upon startup.
- After initialization, the interface will display port status information.

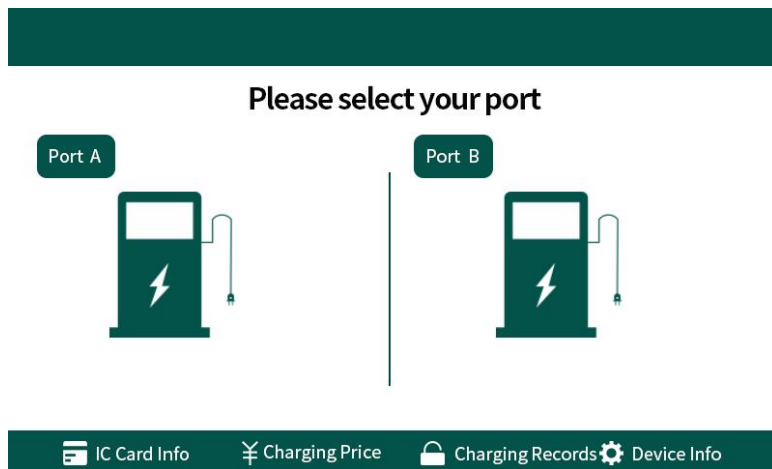

Port Selection

- Click the port labeled "Connected" to access the "Select Charging Method" screen.

As shown in the figure below:

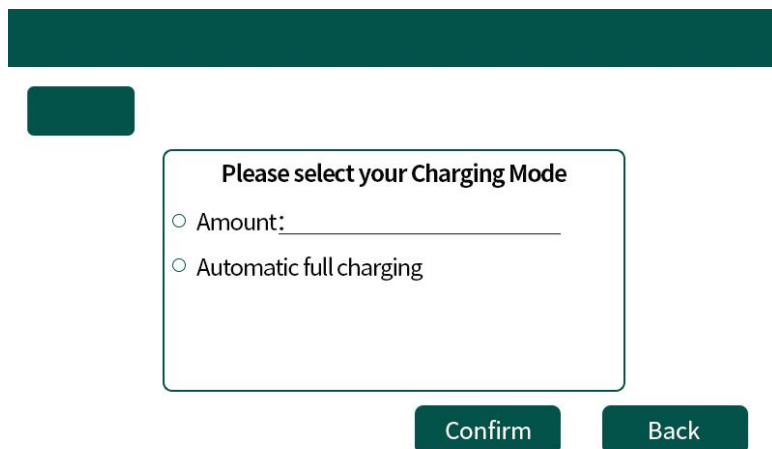

Swipe Card Charging

In the “Select Charging Method” screen, you can:

- Enter the desired amount and swipe a VISA or credit card on the POS terminal to start charging.
- Alternatively, click “Auto Full” and swipe the card to start charging.
- If the POS terminal is not configured, use the charging card provided by our company and swipe it in the designated area on the charger.

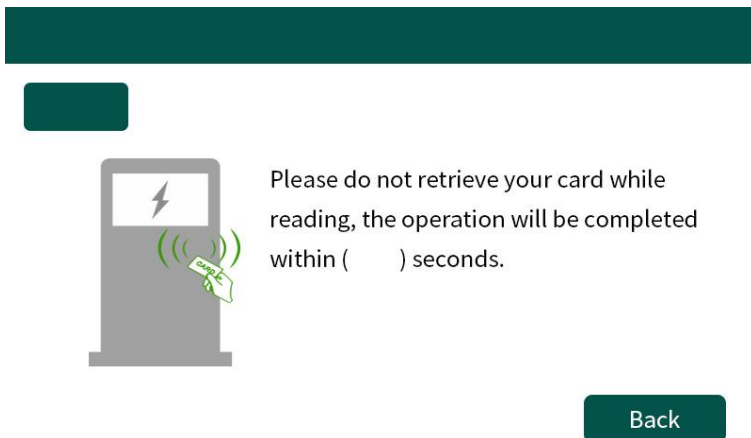

Scan Code Charging:

- Follow the on-screen instructions to scan the code and initiate charging.

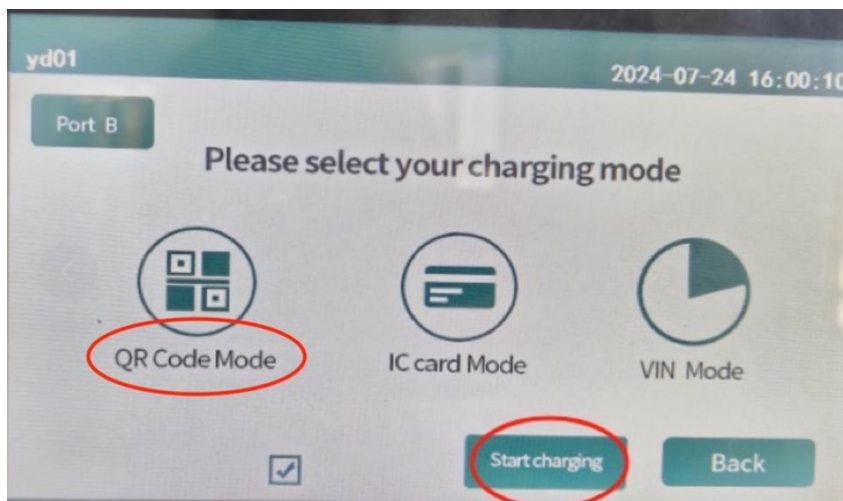

Charging Interface:

- Once charging starts, the interface will display relevant information about the connected port.
- Click “Fee Information” or “Battery Information” to view additional details.

As shown in the following figure:

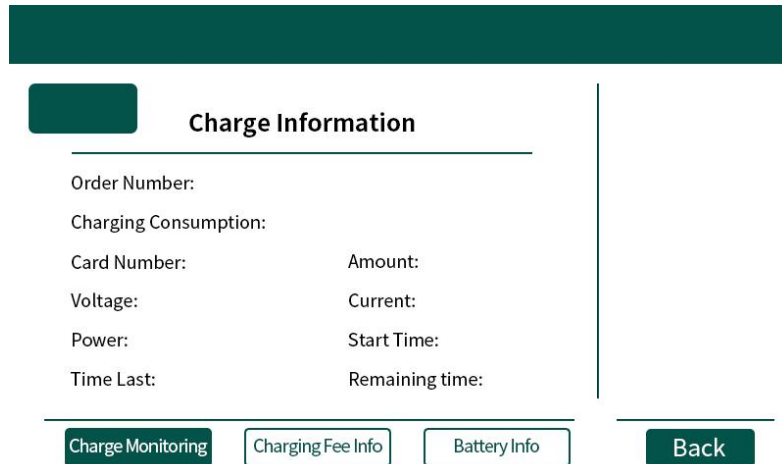

End of Charging

- To end charging, double-click the “End Charging” button on the charging interface.
- The interface will then display the settlement information for the connected port.

As shown in the following figure:

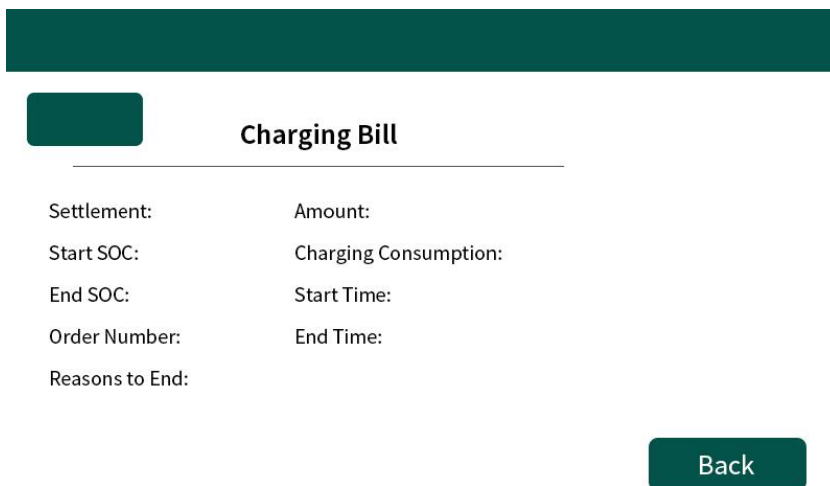

Attention



High Voltage:

Do not pull the connector directly when high voltage is present to avoid damage or serious injury.

Shutdown:

Operate shutdown via the screen or the APP.

Heat:

The EV charger surface may be hot during charging; do not cover vents.

Cleaning:

Do not clean the vehicle or the charger during charging.

Charging connector in place

- After charging is completed, return the charging connector and cable to the EV charger. Hang the charging cable on the hook and insert the connector head back into its seat.

- When the charging connector is connected to the vehicle, ensure the connector head is properly inserted into its seat to prevent dust or water ingress. To prevent the charging cable from causing accidents or tripping pedestrians, always hang the cable on the hook and insert the connector into its seat.

- After use, neatly wrap the cable to maintain its condition.

- To save energy, the EV charger screen will automatically turn off after about 18 seconds of inactivity. The charging connector is designed for 10,000 uses. After exceeding its service life or warranty period (whichever comes first), additional spare parts should be purchased.

- Damage to the charging connector caused by misuse, violence, or illegal operation is not covered under warranty.

- Any financial damages resulting from dangerous or violent operation shall be borne by the operator.

- The charging connector should not be subjected to violent impact, cable twisting, or illegal dragging.

- The operator is responsible for any failures caused by the charging connector being immersed in water without protection.

- Any failures or accidents resulting from exceeding the specified use conditions in this manual shall be borne by the user.

- Minors under the age of 16 are prohibited from operating the equipment. Any responsibility for incidents caused by minors shall be borne by the operator

Charging Abnormalities:

Charging abnormalities are not part of normal charging operations. Refer to this section only in case of abnormalities or misoperations.

- Emergency Stop: In case of an emergency, quickly remove the transparent protection cover and press the red "emergency stop" button. The system will cut off the power supply. Do not use the emergency stop button for normal shutdown.

- Undo the Emergency Stop: Rotate the emergency stop button clockwise to return to the charging state.

- Forced Connector Recovery:

-- Pulling out the charging connector during the charging process is very dangerous and strictly prohibited.

-- If the normal screen stop or swipe card stop operation cannot stop the charging process, press the emergency stop button.

-- Forcing the connector out may cause arc burns and the system will record the fault.

-- Click the confirm button to return to the charging shutdown state.

4.3 OCPP Network Settings

Example Set up access the wss: // dev.optima.az:8314/OCPP/intekdc22

SIM Card:

- ① Insert the SIM card into the OCPP control board;

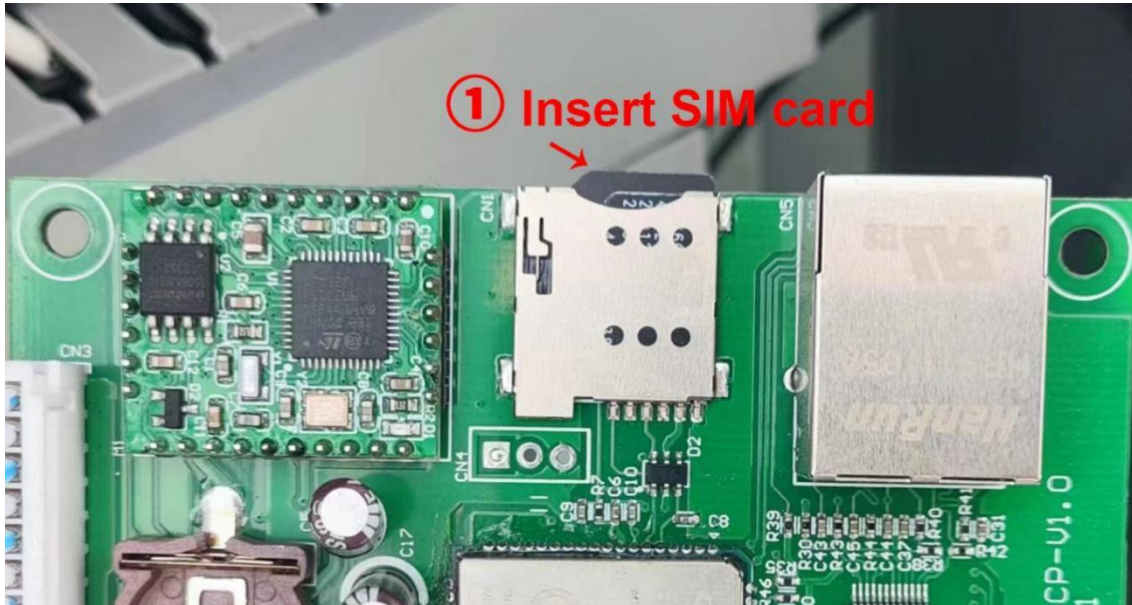

- ② Turn on the single-phase air switch, proceed after the screen is on.

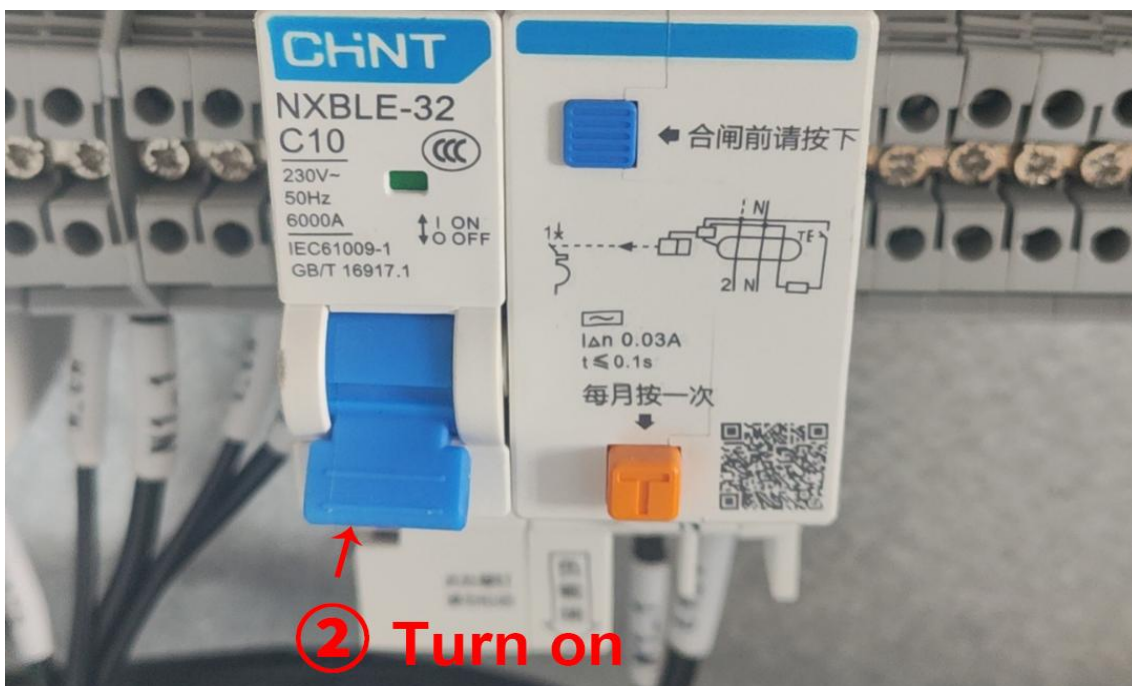

- ③ Double-click the green space above the screen center (as shown below)

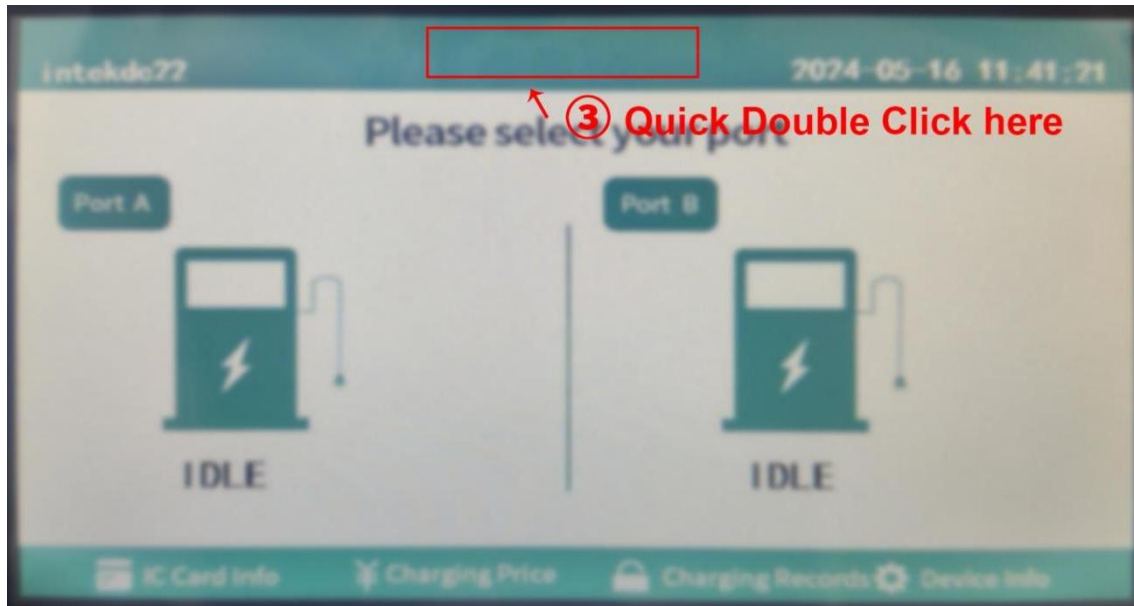

- ④ Click the blank of the input display box and enter 159357

- ⑤ Click "confirm" to enter the Settings interface;

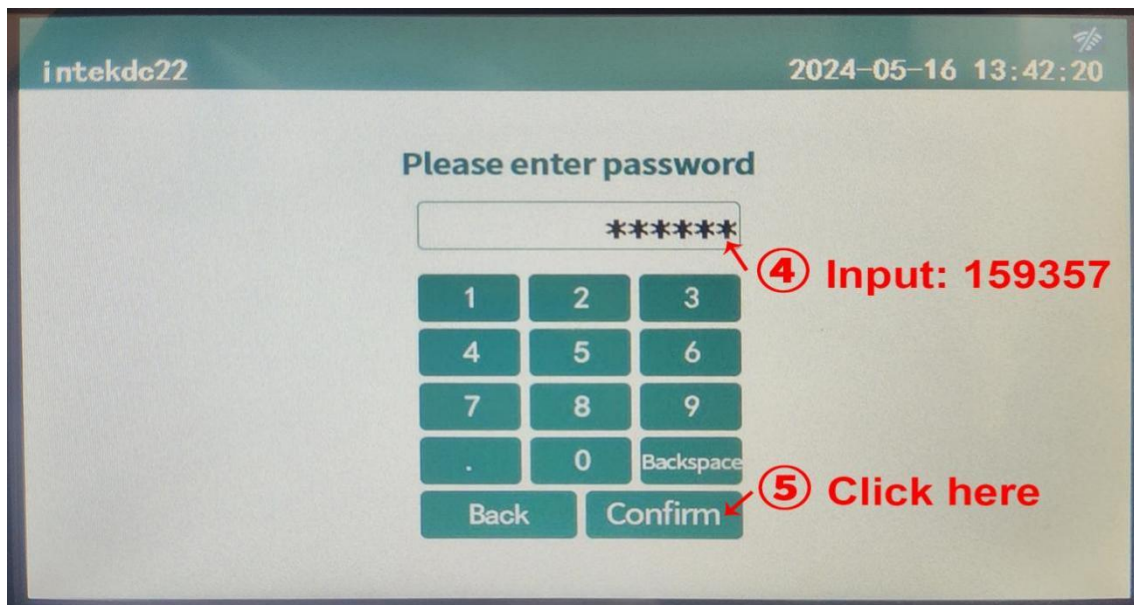

⑥ Set the Charger ID of OCPP (pile given by OCPP provider), and the url of Charger is wss: // dev.optima.

A z: 8314 / OCPP / intekdc22, then enter intekdc22;

⑦ Set the platform to OCPP , if not already set;

⑧ Click "Network Settings", after setting the charger number and charging platform,

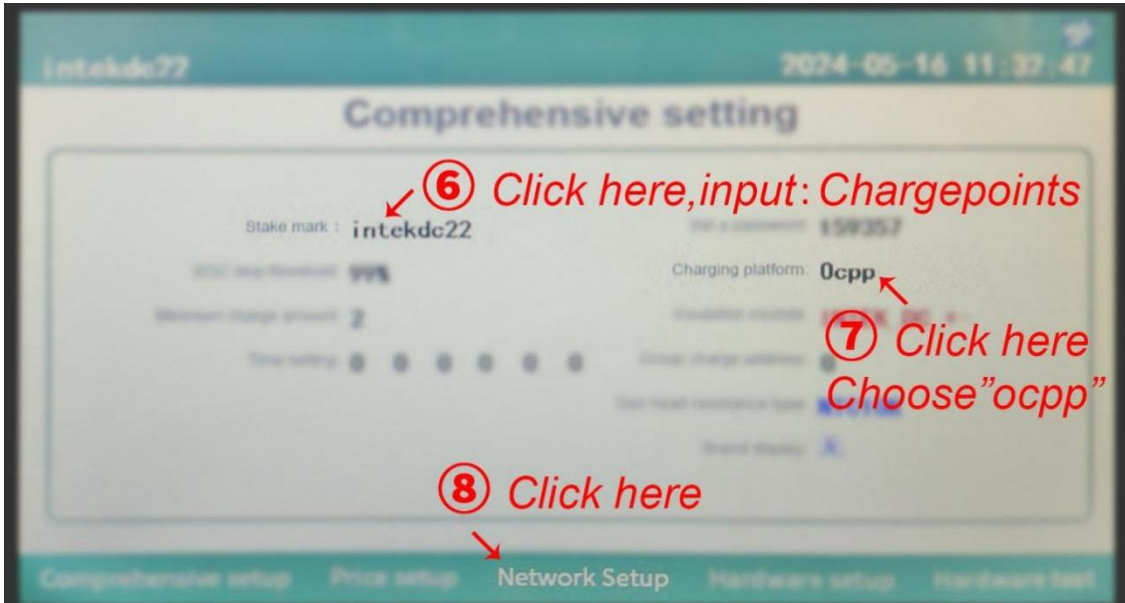

⑨ Click GPRS4G or ETH on the right of the screen, if it is already GPRS4G, no click;

⑩ Adjust OCPP Path: Chargepoints url to wss: // dev.optima.az: 8314 / OCPP / intekdc22, enter wss: // dev.optima. Az: 8314 / OCPP /, then confirm;

*** Note:** Note the double character keys on the keyboard (upper and lower characters), need to use Caps Lock to switch; for example: ':' needs to use Caps lock to input, do not enter ';', click Caps Lock again to switch to normal state before entering letters and numbers.

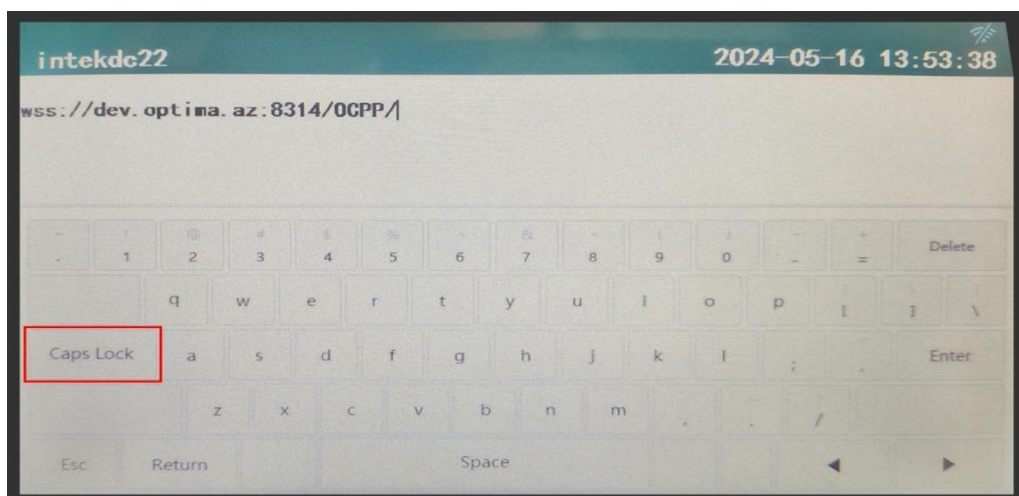

⑪ After returning to the interface, click the bottom left button of the screen to go back to the comprehensive Settings interface. Then, click the bottom left button again to return to the initial interface;

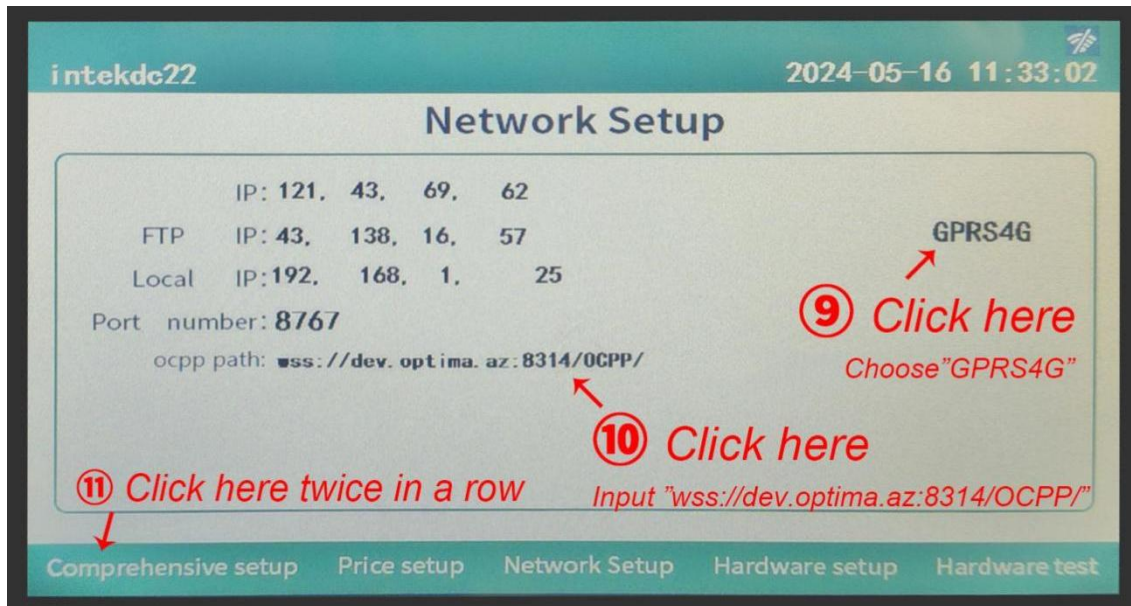

⑫ After returning to the initial interface, restart the charging pile and wait for 1~5 minutes, when the signal mark is displayed in the upper right corner of the screen, the communication is successful;

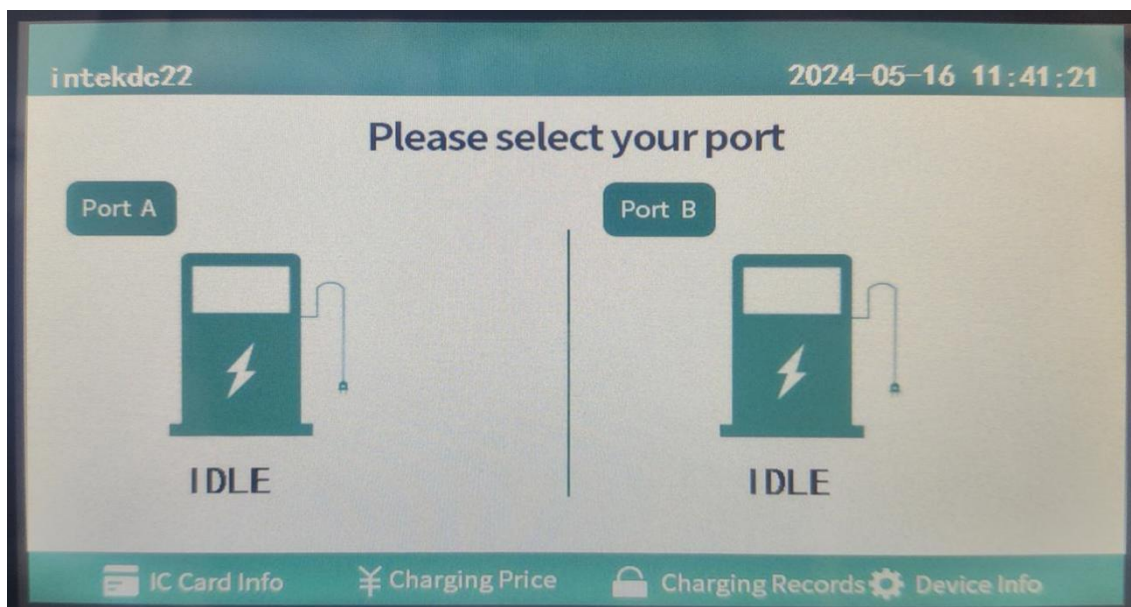

Ethernet cable setup:

- Insert the Ethernet network cable into the subnet cable slot on the OCPP control board (as shown below);
- Follow the same step as described for the SIM card mode;
- Change the Network Setup interface on the right side to ETH.

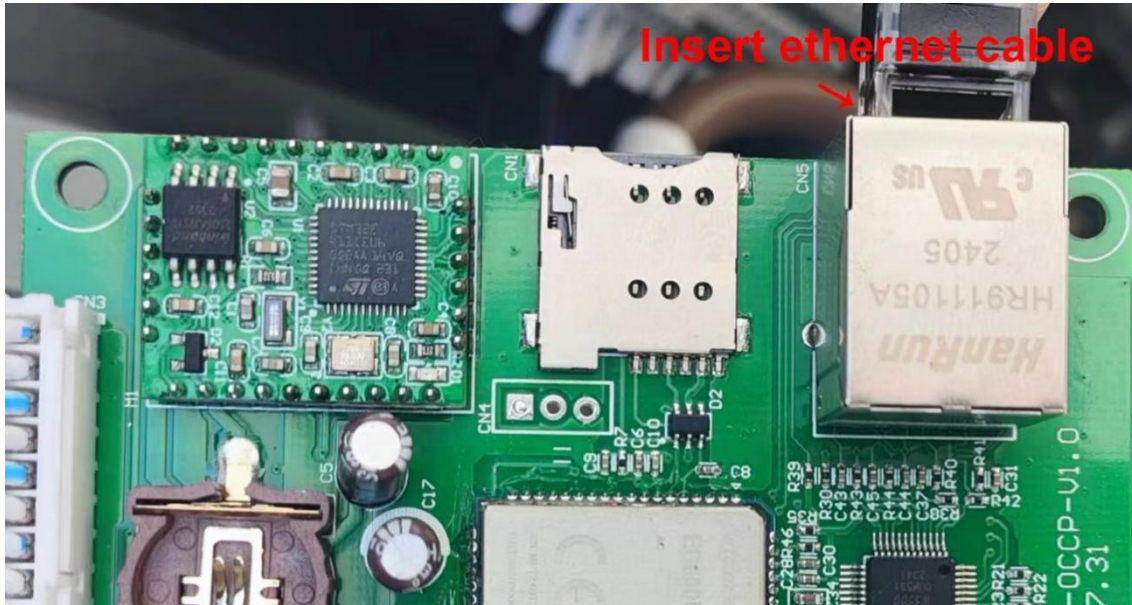

Click ETH on the right of the screen, if it is already ETH.

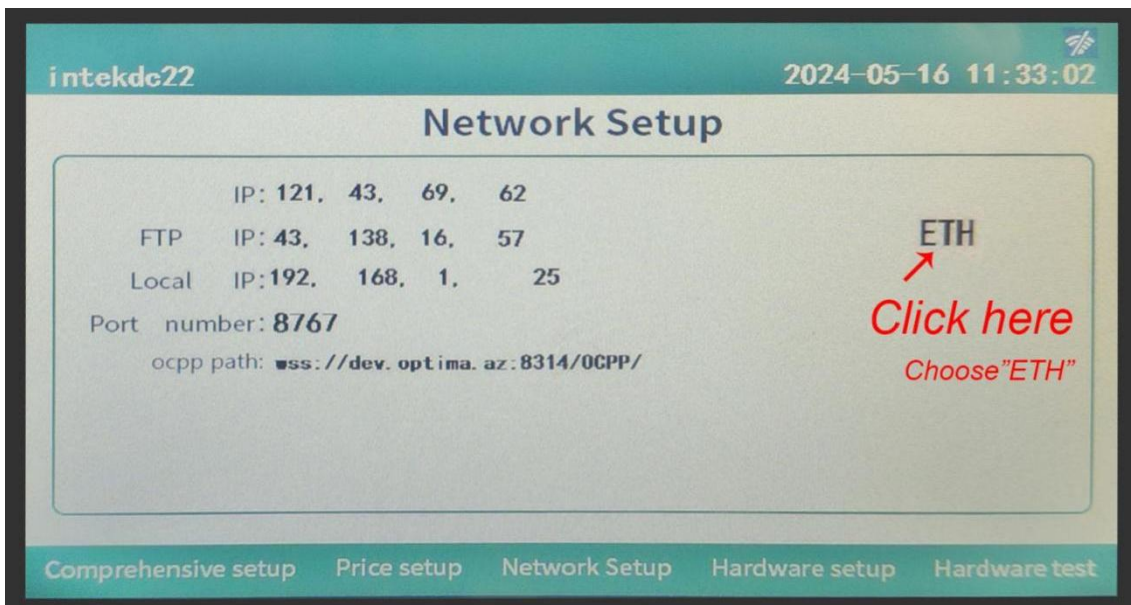

Then return to the original interface, restart and wait for its communication.

4.4 Operational Integration

- After startup, the charger connects with the cloud platform for remote management, diagnostics, and updates.

Integration with Existing Customer Operation Platforms:

- Our company supports integration with existing customer operation platforms through the OCPP protocol.

Please contact our sales or service engineer for assistance.

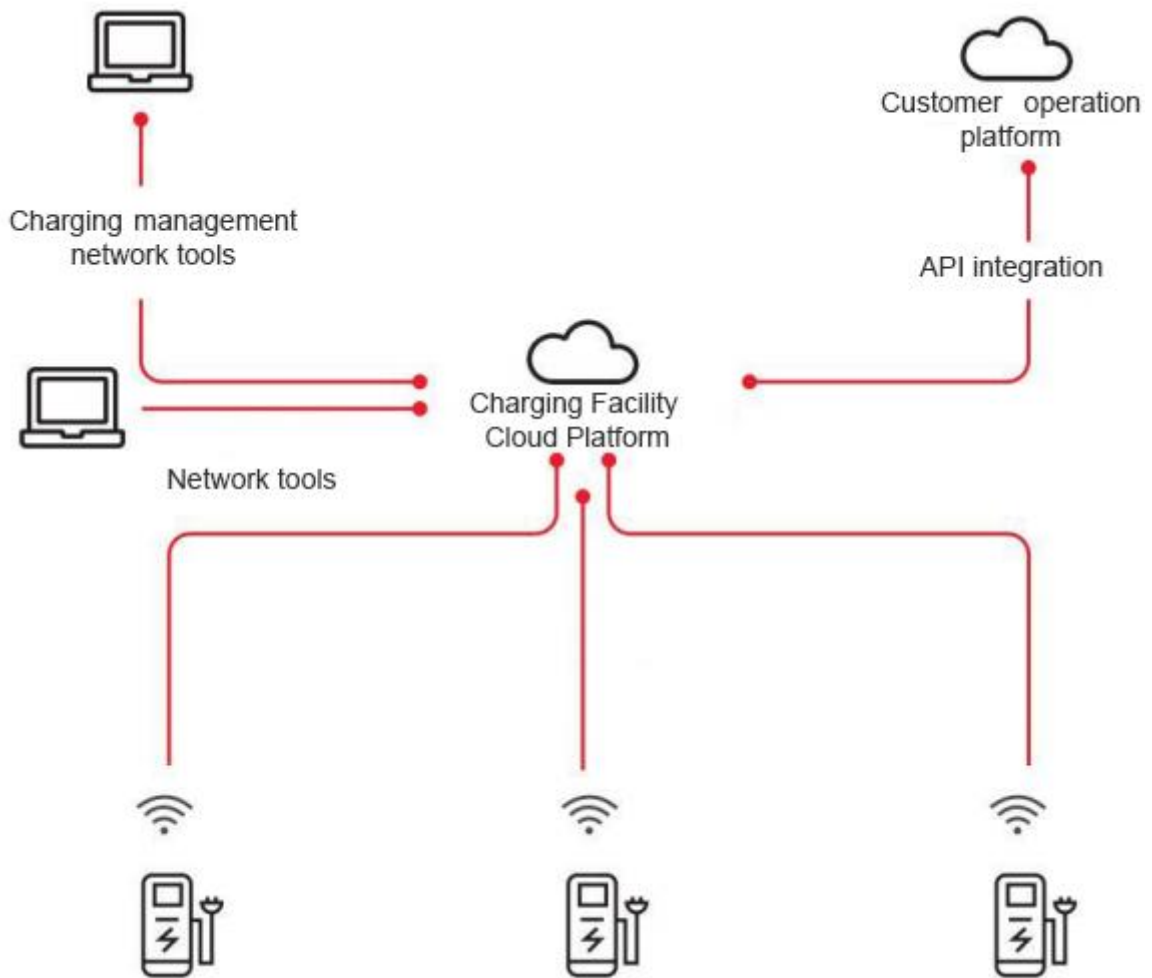

V.Maintenance Instruction

5.1 Daily Maintenance

Daily maintenance can keep the EV charger in a safe and stable and good state.

- Clean up the outer surface of the EV charger every two months
- Tighten the screw bolts at key parts every quarter
- Clean the air filter cotton and dust filter at least once every six months
- Test the leakage protection device once a year

Clean the Appearance

The outer surface of the EV charger is sprayed with powder, which needs to be kept in good state and maintain a beautiful image.

- Stop all the charging process, cut off the power supply, and plug in the charging connector
- Use wet, dust-free cloth to remove foreign matter and dust from the surface of the cabinet
- Only use strong stains with pH between 6 and 8, and then wash with clean water

Test the Electric Leakage Protection Device

Leakage protection is a crucial safety system that must be tested annually. Do not test the device during charging. Ensure all charging processes are stopped and the EV charger is disconnected from the vehicle.

- Open the front and side doors of the EV charger, avoid exposing the open cabinet to stormy weather.
- The EV charger must be in standby mode, which can be activated by touching the screen.
- Press the "Test" button for the leakage protection device:

- OK : The leakage protection device switches to the "off" position, stopping the EV charger. Reset the device by switching to the "on" position.

- Bad: If there is no reaction, disconnect the AC power supply, close the cabinet door, and do not use the charger until the leakage protection device is repaired. Contact our company or local supplier.

- Close the side and front doors of the EV charger.
- Record the time required for testing the leakage protection device annually.

Clean and Replace The Air Filter Cotton and Dust Filter

The EV charger is equipped with air filters to protect electronic components from dust. Clean the air filter and dust gauze at least once every six months.

- Always stop all charging processes before cleaning or replacement.
- Open the side door of the EV charger; avoid exposing the open cabinet to stormy weather.
- Unscrew the hand screws, remove the baffle, and the original air filter.
- Clean debris or dust from the filter and dust gauze.
- Install the cleaned filter, then replace the baffle and screws.
- - Close the side door.



Attention

Operating the EV charger without the air dust filter, or failing to replace it on time, will damage the device. Resulting faults are not covered under the warranty.

5.2 Advanced Maintenance

This EV charger is an Internet of Things (IoT) device with intelligent functions such as pre-charging self-inspection, daily regular self-inspection, and online monitoring of electrical parts and operating parameters.

- Under normal operation, only daily maintenance is required.
- In case of abnormal operation, please refer to the fault handling guidelines.

VI. Fault Treatment

6.1 Fault Identification

The EV charger installed in open places may fail due to various reasons, which should be roughly identified:

Improper Use of Fault

- Emergency stop button pressed
- Forced connector pulled

Charging System Failure

- See the list in the "Processing Methods" later

Electric Vehicle System Failure

- Abnormal system faults, abnormal voltage, abnormal insulation and other faults of electric vehicles will

lead to charging failures.

Man-made Fault Destruction

- the charging connector to crack, press, soak water
- The charging cable is rolled over and pulled by the wheel
- The charging cable is pulled and broken by the external force
- the EV charger is hit by a driving vehicle or a heavy object
- The door of the EV charger cabinet is opened abnormally
- Air duct blockage, etc

Note, human damage failure is not within the scope of warranty service

Natural Disaster Failure

- Earthquake damage
- Heavy rain flooding
- Lightning disaster
- An external fire

Note, the natural disaster failure is not within the scope of the warranty service

6.2 Treatment Method

No.	Display Status	Possible Cause	Suggest How to Deal With	Preliminary Treatment Party
1	Black screen, no touch response	AC input to the charging station is off	Check if the charger's input power supply is normal:ensure each phase of the two-phase input voltage is ~220V, with a line voltage of ~380V. Inspect for any leakage or short circuits in the input cable. If input is normal, try restarting. If the issue persists, contact our service personnel.	Customer operation and maintenance / Company service
2	Screen Flickering, white screen, incorrect display	Continuous 24-hour operation causing display freeze	Try restarting the power. If the issue persists, contact our service personnel for assistance.	Customer operation and maintenance/ Company service
3	Display: insulation detection fault	Insulation fault in the vehicle or EV charger	Replace the EV charger and attempt charging again. If the problem persists, it is likely an issue with the vehicle. If the fault does not recur, it indicates a problem with the EV Charger. Contact our service personnel for further assistance.	User/ Company service
4	Other issues not listed above	Various potential causes	Contact our service personnel for further assistance.	Company service

6.3 Maintenance Records

No.	Fault Description	Maintenance Method	Result	Attendant	Date	User
1						
2						
3						
4						
5						
6						
7						
8						

The above forms are used for maintenance records.

User Name (Company / Mr. / Ms.):

contact number:

installation time:

VII.After-sale Service

When the product becomes unusable, please contact us through your local operator. We will arrange for professional engineers to provide remote guidance until the issue is resolved.

Alternatively, you may email us with your requirements, and we will promptly provide the necessary assistance.

Email address: heshiyu.1988@163.com

Technical data of European standard 320KW DC charging pile

1.1 Technical parameters

No.	Project	Technical parameter	Remarks
1	Number of charging interfaces	2	
2	Rated voltage	400V	
3	Rated frequency	50Hz	
4	Input voltage	400V±15%	
5	Output voltage	200V-1000V	
6	Rated output current	320A	
7	Output maximum power	320KW	
8	CI	4G wireless networking, wired networking	Apolegamy
9	Communicating protocol	Cloud fast charge V1.5/OCCP1.6	polegamy
10	Input mode	Touch	
11	Starting mode	Credit card startup / POS machine payment / scanning code payment on cloud platform	Optional POS machine payment, cloud platform scanning code payment
12	Display screen	7inch color industrial-grade display screen	
13	Monitoring platform	Integrated card issuing, operation, monitoring and maintenance in one	
14	Dielectric strength	≥2000V	
15	Leakage current	≤3.5mA	
16	Levels of protection	IP54	
17	Work environment	-20~50°C	

18	Working humidity	5%-95%	
19	Interface type	European standard CCS2	
20	Measurement function	Electricity meter measurement	
21	Protocol standard	ISO15118/DIN70121	
21	Cooling-down method	Air blast cooling	
22	Defensive function	Over voltage short circuit protection, overload protection, leakage protection, surge protection reverse connection protection, over temperature protection, output over-undervoltage protection, etc.	
23	Way to install	Integrated	
24	Power factor	0.99	
25	Overall efficiency	94%	

1.2 Technical features and overview

Our independent research and development of charging equipment follow the international practice using the design concept of intelligent, modular, a complete set of charging control system, charging control unit, human-computer interaction unit, charging module unit, dc distribution unit, etc, system configuration RS485 \ CAN interface \ Ethernet \ PLC, select European regional CCS 2 standard charging connector.

This product has the following characteristics:

(1) Adopt the world's advanced constant power charging module, constant power range of 300-1000V, low voltage section can maintain a large charging power, bring you a rapid charging speed;

(2) Adopt module structured design, multiple modules work in parallel, and module faults automatically exit to improve customer experience;

(3) The monitoring unit adopts the distributed control mode to control risks to the greatest extent and improve the reliability and safety of the charging equipment. The man-machine interface is friendly (both Chinese and English interfaces can be provided). Click the touch screen for charging order query and system parameter setting, and the operation is simple and convenient.

(4) Our company has developed advanced flexible intelligent control technology, intelligently distributes dual-port charging power, comprehensively control the charging process according to pile, car, environment, people and other factors, to ensure that the battery works in the best state, extend the service life of the battery pack of the vehicle and machine, and meet the needs of customers for short time and quick charging.

(5) Strong Internet service capability enables the product to access the Internet through GPRS / 4G module, realize interconnection with background management system platform, interactive real-time data, remote start-stop and payment processing; support OCPP 1.6 protocol to help you take the lead in business operation;

(6) It can be configured with global POS machines, and support multiple global credit card payment channels, such as UnionPay and VISA, to solve the operation and payment problems of foreign commercial charging stations.

1.3 Function introduction

(1) Charging mode: During the charging process, the integrated charger dynamically adjusts the charging parameters and performs the corresponding actions according to the data provided by the ev battery management system, the charger self-check parameters and the instructions issued by the server, and automatically stops the charging process.

(2) Metering function: a smart electricity meter is installed inside the pile body to measure the output electric energy of the DC charger. The electricity meter is installed on the outlet side of the charger. It can also be adjusted to the incoming line side according to the owner's requirements.

(3) Charging function: It supports charging according to charging power, and supports the configuration of parameters including rate time, charging unit electricity, charging rate and so on. The accounting management module reads the electricity data of the electricity meter in real time, and sets the electricity price of the electricity meter. Single unit can support self-built contactless IC card loaded with user information and amount information, and optional POS machine to support credit card payment.

(4) Human-computer interaction function: The man-machine interface adopts color LCD touch screen, the operation interface displays complete and rich information, convenient operation, friendly interface, equipped with card swiping, emergency stop button and other operation

interfaces. At the same time, the man-machine interface can record and display the charging current, charging voltage, charging time, charging power and error information during the charging process; Users can query personal information and pile information at the pile end, or set personal information such as password modification.

(5) Display function: mainly display power supply, charging, fault state indication, charging voltage, charging current, charged amount, highest and minimum voltage of vehicle battery, vehicle SOC, estimated remaining charging time, fault and alarm information; under the administrator authority, set pile IP address, coding, highest / minimum output voltage, maximum output current and other information, or query the factory setting information; clear and complete, which can be identified without ambient light source.

(6) Communication function: The PLC interface communicates with the ev battery management system to obtain the charging parameters and real-time charging data of the ev battery system. It has the function of communication with the superior monitoring system, supports GPRS wireless communication, Ethernet and other communication modes, and meets the relevant encryption requirements.

(7) Emergency stop function: with emergency stop function, can emergency stop charging through manual switch or superior monitoring communication command.

(8) Charging monitoring function: with the functions of leakage current monitoring, insulation monitoring and alarm, the sound and light alarm can be conducted through the LED indicator light. The charger monitors the status of the battery, and automatically adjusts the charging curve, charging current, single battery capacity and charging voltage according to the temperature and voltage of the battery.

(9) Protection and alarm function: when the DC output is overcurrent, the charger will automatically cut off the DC output and issue an alarm signal. When the DC output is short circuit, the charger automatically enters the current limiting output state; when the AC / DC conversion power unit is over warm, the charger automatically cuts off the DC output and sends an alarm signal. The charger has the function of lightning protection and surge protection, and has the function of preventing battery current backflow.

(10) Record storage function: monitoring has alarm record and event storage function, and can store historical charging consumption information.

(11) Emergency power off treatment: When the emergency stop button, control and guidance

fault, communication fault of the charging management system, the charging machine can disconnect the DC output contactor within 100ms, and the output voltage drops to less than 60V within 1s.

(12) Over-temperature protection: the charger monitors the temperature of the charging gun and the temperature of the pile in real time. If the temperature occurs, the power is reduced until the charging is stopped.

(12) Remote upgrade function: the charger can remotely upgrade the program through the background management platform.

(13) Others: fully consider the security of the equipment: configure the access control switch, open the cabinet door for automatic alarm, to avoid live operation;

1.4 Renderings

